

SERVING
INDUSTRY for
50
years
SINCE 1969

PRODUCT BROCHURE



**LEADERS IN
WORLD CLASS
PRECISION
ENGINEERING**

www.hofmannengineering.com

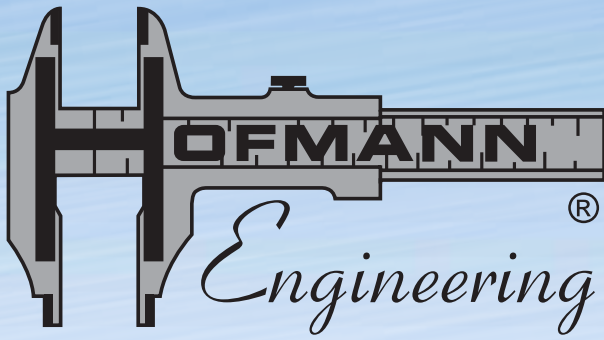

INTRODUCTION

Hofmann Engineering was founded by brothers John and Erich Hofmann in 1969 and is a successful family owned and operated manufacturing-engineering business. Hofmann Engineering offers expert precision engineering solutions to a wide range of industries including mining and minerals processing, defence, transport, energy, manufacturing and agriculture. With its Headquarters in Perth, Western Australia, and factories and offices through-out Australia and overseas, Hofmann Engineering's high quality products and services are sought locally and globally. Quality Assurance accreditation by Lloyds (LRQA) complements the total quality culture.

Disciplined financial management and operational excellence have enabled Hofmann Engineering to grow into one of the largest privately owned engineering businesses in Australia, employing over 500 people world wide. In 2003 leadership of Hofmann Engineering was passed to the second generation with John's son Erich J Hofmann now leading the company in their continued pursuit of excellence.



Board of Directors (pictured left to right):

Leighton White - Technical Director | **Erich J Hofmann** - Managing Director
John P Hofmann - Owner/Director | **Erich F Hofmann** - Owner/Director

AUSTRALIA: PERTH | MELBOURNE | BENDIGO | NEWCASTLE
INTERNATIONAL: CHILE | PERU | INDIA | CHINA | NORTH AMERICA

Pictured below:
Corporate Headquarters
Perth, Western Australia

CONTENTS

INTRODUCTION.....	2
GLOBAL FACILITIES.....	4
HOFMANN ENGINEERING EVOLUTION.....	6
HOFPARTS.....	7
APPRENTICE & ENGINEER TRAINING PROGRAMS.....	8

MINING - FIXED PLANT EQUIPMENT

MILLS & KILNS.....	9
MILL & KILN PINIONS.....	11
MILL & KILN GIRTH GEARS.....	13
FORGED STEEL FABRICATED GIRTH GEARS.....	15
HOFALIGN - FORGED STEEL GIRTH GEARS.....	17
OPEN GEAR RECONDITIONING PROCEDURE.....	19
GRINDING MILL SHELLS & HEADS.....	21
KILN SERVICES..... (SEE SERVICES SECTION)	
GEARBOX RANGE.....	23
GEARBOX REBUILDS.....	25
SELF ALIGNING DRIVES.....	27
BEVEL & WORM GEARING.....	29
HPGRs.....	31
CRUSHERS.....	33
FULLY FORGED CRUSHER HEADS.....	35
APRON FEEDERS.....	36
HOFNUTS.....	37
DISC VACUUM FILTERS.....	39
VALVES & PUMPS.....	41
WINDER COMPONENTS.....	43
VIBRATING SCREENS.....	45

MINING - MOBILE MINING EQUIPMENT (MME)

UNDERGROUND MINING.....	46
DRAGLINES.....	47
ELECTRIC ROPE SHOVELS.....	51
HYDRAULIC EXCAVATORS.....	55
SLEW BEARINGS.....	59
TRACK PADS.....	61
SELF ALIGNING DRIVES... (SEE MINING FIXED PLANT EQUIPMENT SECTION)	
HAUL TRUCKS.....	65

STACKERS & RECLAIMERS.....	67
----------------------------	----

DEFENCE

DEFENCE.....	69
BOW THRUSTERS.....	72
ANZAC CLASS FRIGATES.....	73
NAVAL SUBMARINES.....	74
SPACE SURVEILLANCE TELESCOPE.....	75

TRANSPORT

AEROSPACE.....	77
RAIL.....	79
BOW THRUSTERS..... (SEE DEFENCE SECTION)	

ENERGY

OIL & GAS.....	81
WIND TURBINE GEARBOXES.....	83
VALVES & PUMPS..... (SEE MINING FIXED PLANT EQUIPMENT SECTION)	
POWER STATIONS.....	85
HYDRO POWER.....	87

MANUFACTURING

GEAR MANUFACTURE.....	89
HOFMANN PORTABLE MACHINE TOOLS.....	91
HOFNUTS..... (SEE MINING FIXED PLANT EQUIPMENT SECTION)	
CUTTING TOOLS.....	93
FOOD PACKAGING.....	95
PRESS SHOP.....	97
AEROSPACE TOOLING..... (SEE TRANSPORT SECTION)	

AGRICULTURE

SUGAR MILLS.....	99
------------------	----

SERVICES

SITE SERVICES.....	101
KILN SERVICES.....	103
GEARBOX REBUILDS..... (SEE MINING FIXED PLANT EQUIPMENT SECTION)	
METROLOGY, DESIGN & METALLURGICAL SERVICES ..	105
WORKSHOP CAPACITY.....	107



AUSTRALIAN OPERATIONS



• Hofmann Engineering **BENDIGO**, VIC



• Hofmann Engineering **MELBOURNE**, VIC



• Hofmann Engineering **NEWCASTLE**, NSW

INTERNATIONAL OPERATIONS



• Hofmann Engineering **CHILE**



• Hofmann Engineering **NORTH AMERICA**



• Hofmann Engineering **PERU**

Sales and engineering sourcing offices with detailed metallurgical, mechanical and inspection capability:

- Hofmann Engineering **CHINA**
- Hofmann Engineering **INDIA**
- Hofmann Engineering **USA - TEXAS**

GLOBAL OPERATIONS

GLOBAL OPERATIONS & AGENTS



HOFMANN MANUFACTURING SITES



HOFMANN PREMISES/OFFICES



HOFMANN AGENTS/DISTRIBUTORS

PLEASE SEE

www.hofmannengineering.com

FOR MORE INFORMATION REGARDING
AGENTS AND REPRESENTATIVES

HOFMANN ENGINEERING EVOLUTION

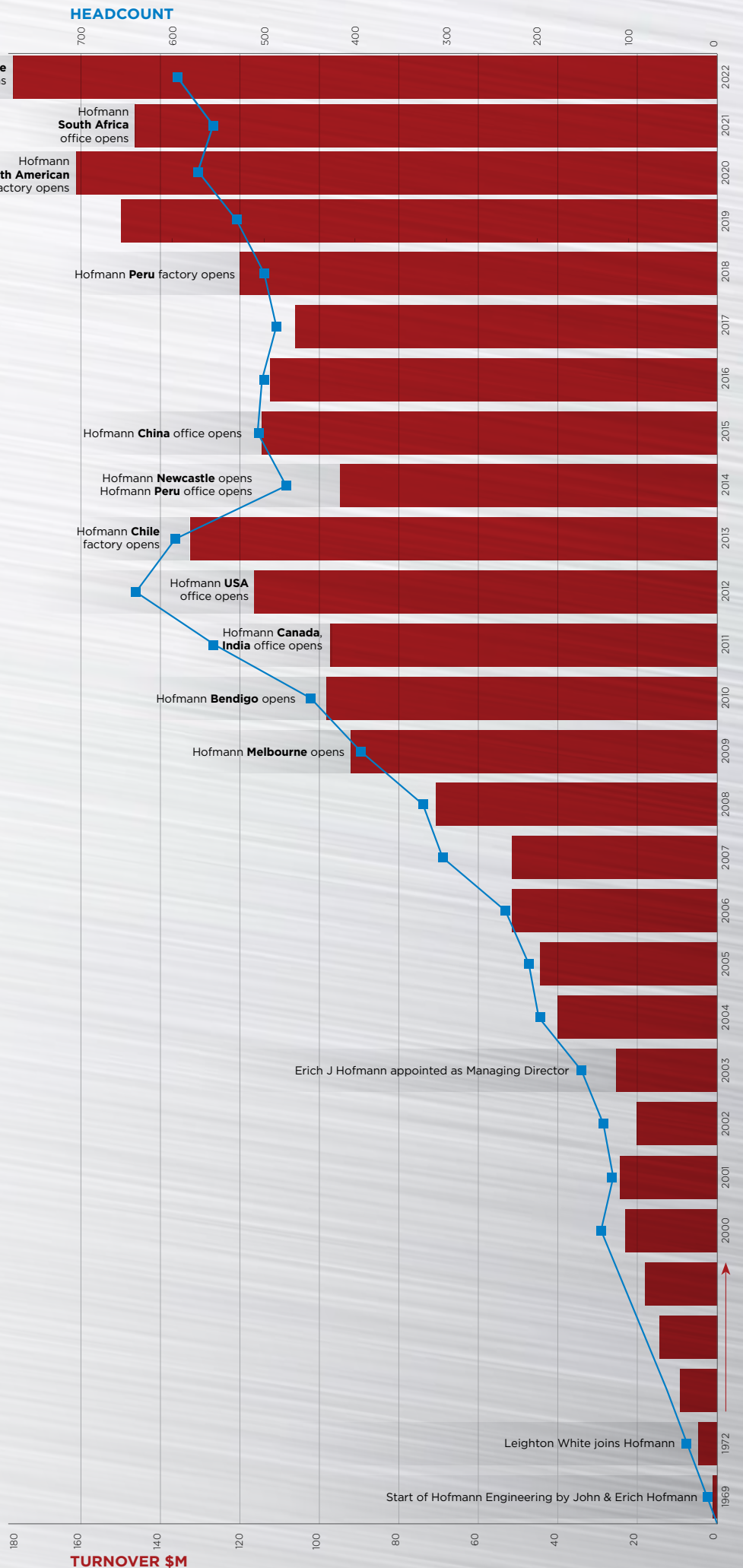
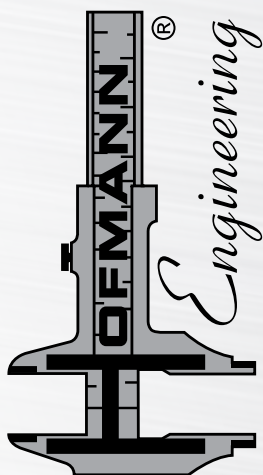

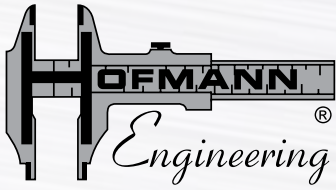

SERVING
INDUSTRY
SINCE 1969

HOFMANN CERTIFICATIONS

**AEROSPACE/DEFENCE
AS9100**



**QUALITY, SAFETY & ENVIRONMENT
ISO9001, ISO45001, ISO14001**



**WELDING
EN15085-2, ISO3834 PART2**

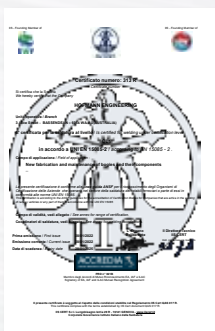
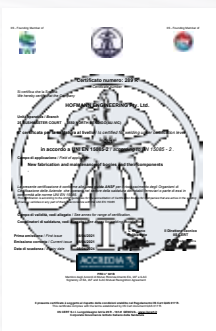

**AGMA
(AMERICAN GEAR
MANUFACTURERS ASSOC.)**



**ITAR
(INTERNATIONAL TRAFFIC IN
ARMS REGULATIONS)**



**DISP - PHASE 1
CYBER SECURITY - ISO27000**

HOFMANN ENGINEERING
COMPLIANT FOR F35
JOINT STRIKE
FIGHTER PROGRAM

HOFMANN ENGINEERING PTY LTD

3 Alice Street, Bassendean (Perth) Western Australia 6054 T +61 8 9279 5522 E mail@hofmannengineering.com

© Copyright 2022, Hofmann Engineering Pty Ltd

AUSTRALIA: PERTH | MELBOURNE | BENDIGO | NEWCASTLE
INTERNATIONAL: CHILE | PERU | INDIA | CHINA | NORTH AMERICA | SOUTH AFRICA

www.hofmannengineering.com

HOPARTS

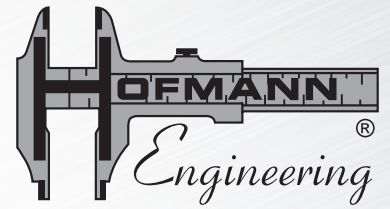

HOPARTS connects you to our extensive catalogue of parts from anywhere in the world: from the mine site to your capital city office.



ORDER PARTS WITH DETAILED INFORMATION



OR....REQUEST A QUOTE TODAY!

Online Store

Cart Details

[Add your own part](#) [SAVE CART](#) [CLEAR CART](#)

You have 0 items in your cart.

Cart Id: Not Saved Cart Status: Active Description: [REQUEST QUOTE](#)

[REQUEST QUOTE](#)



www.hofparts.com

APPRENTICE & ENGINEER TRAINING PROGRAMS

“Hofmann Engineering has given me the career opportunity of a lifetime”

*David Nolan,
Hofmann Apprentice of the year 2018*



INVESTING IN THE FUTURE

To achieve the production and supply of niche products and services requires Hofmann Engineering to train its own expert, specialist tradespeople and engineers.

Hofmann Engineering has a strong and ongoing commitment to training apprentices, with their apprenticeship program running continuously since the 1970's. The apprenticeship program provides apprentices with a structured and challenging education in their chosen trade. Hofmann Engineering is proud of the reputation of their apprenticeship program with its craftspeople eagerly sought on completion of their training.

Hofmann Engineering works closely with engineering universities and provides many opportunities to student engineers, from site visits to work experience and cadetship. Many cadet engineers have had the opportunity to write their thesis on topics at Hofmann Engineering to push the boundaries of existing knowledge.

OUR FUTURE is in HOFMANN TRAINED APPRENTICES & ENGINEERS

APPROXIMATELY 20% OF OUR 550 STAFF ACROSS OUR 6 FACTORIES ARE HOFMANN TRAINED APPRENTICES OR CADET ENGINEERS.

MILLS & KILNS

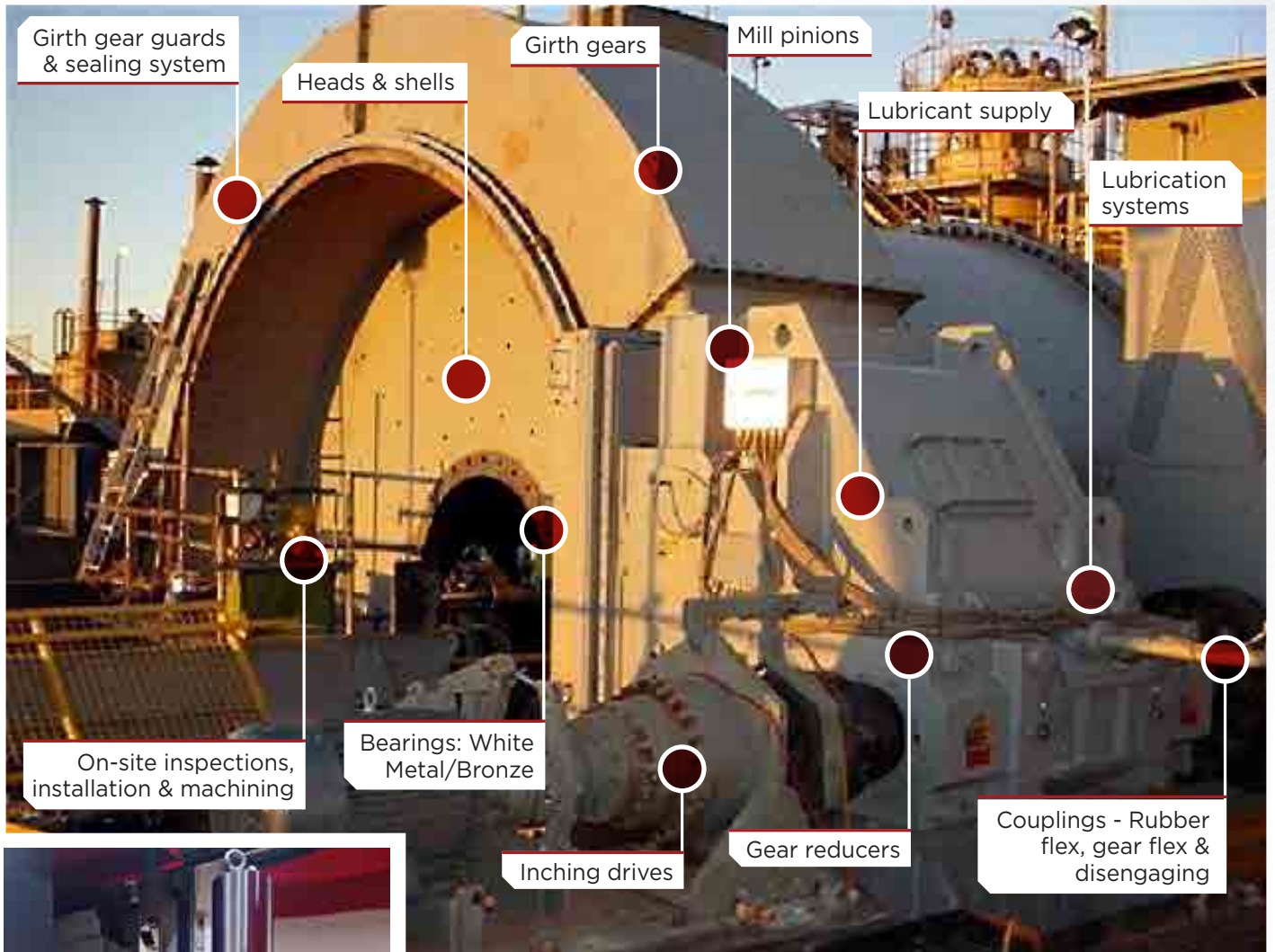

PINIONS

1. Through hardened
2. Induction hardened
3. Case carburised
4. Self aligning

CAPACITY

Size: 1.6m face width x 6m long.
Hardness: to 62HRC.
Quality: AGMA 15 (DIN 2).

GIRTH GEARS

1. SG iron
2. Cast steel
3. Austempered SG iron
4. Forged fabricated
5. Forged fabricated, induction hardened

CAPACITY 15m (50ft)

Size: 2.5m face width x 15m diameter.
Hardness: to 52HRC (500BHN).
Quality: AGMA 10 (DIN 7).



SELF-ALIGNING DRIVES

- Automatically maintains 100% gear contact regardless of movement in foundations and/or driven component.
- Can use recirculating filtered oil.
- Reduced maintenance as alignment checks and adjustments are eliminated.
- Power to 10,000kW per gearbox.



STANDARD GEARBOXES

- Completely designed and manufactured in-house to AGMA, DIN or ISO standards.
- Standard range of multi-stage drives.
- Precision case-carburised and ground gearing to AGMA 15 (DIN 2) for quiet, reliable operation.



SPECIAL GEARBOXES

- Special gearboxes can be designed to fit existing foundations as a direct replacement of old drives. (Flender, Falk, Valmet etc.).
- Power upgrades, ratio changes and replacement parts available.
- Torque-splitting gear drives.



INCHING DRIVES

A range of inching drives to fit new and existing mill and kiln drives. Features include:

- Planetary main reduction
- Hydraulic or electric
- Integral or separate brakes
- Disengaging couplings



GEAR PROTECTION SYSTEMS

- Continuous & intermittent grease spray systems.
- Re-circulating filtered oil systems.
- Infrared temperature monitoring systems.
- Measures gear mesh temperature.
- Sealing systems for girth gears and trunnion bearings.



LUBRICANT SUPPLY

Hofmann's lubrication division has an agreement with Kluber Lubrication Germany AG to supply a range of products, directly formulated to protect the gearing that we design and manufacture.

This forms an integral part of **Hofmann's Gear Protection Package** used to improve the life of high performance gearing.



ON-SITE MACHINING

- Flange and journal machining to 14m dia.
- Line boring and drilling to 3m dia x 6m L.
- Grinding and finishing of kiln tyres.
- Milling of keyways and surfaces.
- Welding and heat-treatment.
- Bolt tensioning.
- Special purpose machinery designed and manufactured to suit the application.



ON-SITE INSPECTION & CONSULTING SERVICE

- Inspection and assessment of mill and drive trains.
- Failure analysis including Engineering and Gearing design review. Finite Element Analysis and Metallurgical Analysis.



SITE SERVICES

- Laser alignments of drive trains
- Girth gear/pinion installation.
- Reconditioning of worn gearing using case hardened pinions and chemical etchant.
- Trunnion bearing installation including scraping in of white metal bearings.

MILL & KILN PINIONS

Specialising in the design and manufacture of mill and kiln pinions of all sizes and specifications. A range of heat treatment options including case carburising, quench and tempering, and induction hardening are available. Pinions can be finish ground to achieve a superior quality level. Old, worn, existing pinions with unknown geometry can be easily replaced with a product improved pinion.



PINIONS

1. Through hardened
2. Induction hardened
3. Case carburised
4. Self aligning





CAPACITY

Size: 1.6m face width x 6m long.
Hardness: to 62 HRC.
Quality: AGMA 15 (DIN 2).



LARGE PINION RATING COMPARISON

The effect of different design and manufacturing processes on hardness and quality.

	QUENCH & TEMPERED (SOFT)		INDUCTION HARDENED & GROUND		CARBURISED & GROUND		CARBURISED & SELF ALIGNING	
MATERIAL	AISI 4340	MAX	AISI 4340	MAX	EN10084 18CrNiMo7-6	MAX	EN10084 18CrNiMo7-6	MAX
HEAT TREATMENT Hardness	QUENCH & TEMP 320 BHN	370 BHN	INDUCTION HARDENED Core = 300 BHN Case = 56 RC Depth = 7mm	400 BHN 60 RC 10mm	GAS CARBURISED Core = 400 BHN Case = 60 RC Depth = 5mm	420 BHN 62 RC 6mm	GAS CARBURISED Core = 400 BHN Case = 60 RC Depth = 5mm	420 BHN 62 RC 6mm
QUALITY Machining	AGMA 10 (DIN 7) Hobbed	11	AGMA 12 (DIN 5) Ground	15	AGMA 12 (DIN 5) Ground	15	AGMA 12 (DIN 5) Ground	15
PICTURES DEPICT TYPICAL PINION TYPES BEING MANUFACTURED BY HOFMANN ENGINEERING								
EXAMPLE: Power Details: Power (kW).....3500 Speed (RPM).....200								
GEOMETRY								
Module Mn 25.4 Pressure Ang a 25° Helix Angle β 0 Nos Teeth Z 25 Face Width F 710 Overall Length L 2840 Outside Dia da 702 Weight (Kg) W 2720	Mn max = 100 a max = 45° β max = 45° Z max = 600 F max = 2500mm L max = 12000mm da max = 8000mm W max = 100 tonne		Mn max = 32 a max = 45° β max = 45° Z max = 600 F max = 1200mm L max = 6000mm da max = 3000mm W max = 20 tonne		Mn max = 32 a max = 45° β max = 45° Z max = 600 F max = 1200mm L max = 3700mm da max = 1900mm W max = 20 tonne		Mn max = 32 a max = 45° β max = 45° Z max = 600 F max = 1200mm L max = 3700mm da max = 1900mm W max = 20 tonne	
% PRICE	100%		140%		110%		160%	
DELIVERY	18 weeks		21 weeks		19 weeks		24 weeks	
AGMA 6115-B15 Pitting Csf Strength Ks F	1.04 2.01		2.10 2.26		2.44 2.53		3.68 3.82	

LARGE PINION RATING COMPARISON

■ Pitting Csf
■ Strength Ksf

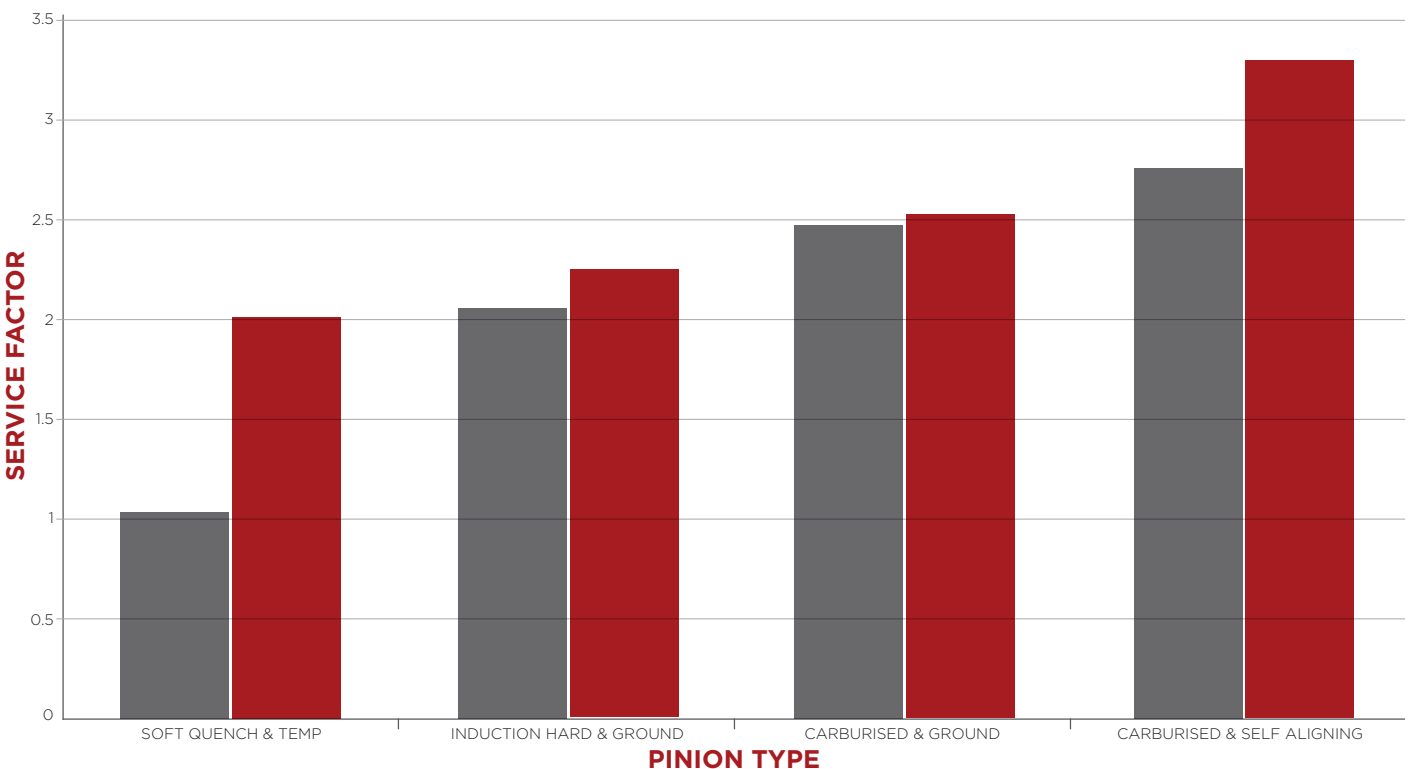

MILL & KILN GIRTH GEARS

to 15m (50ft)



Specialising in the design and manufacture of large mill and kiln girth gears up to 15 meters in diameter. New designs or direct replacements of existing gears can be manufactured. Materials offered include forged fabricated steel, spherical graphite iron (SGI) or cast steel. A range of finish machining options are available including a number of specialised gear tooth cutting machines. Old, worn, existing gears with unknown geometry can be easily replaced with a product improved gear.



GIRTH GEARS

1. SG iron
2. Cast steel
3. Austempered SG iron
4. Forged fabricated
5. Forged fabricated, induction hardened

CAPACITY 15m (50ft)

Size: 2.5m face width x 15m dia.
Hardness: to 52HRC (500BHN).
Quality: AGMA 10 (DIN 7).

GIRTH GEAR RATING COMPARISON

The effect of different material and heat treatment on hardness and quality.

MATERIAL	SG IRON NORMALISED INDIVIDUAL RISER		CAST STEEL NORMALISED FULL RING RISER		AUSTUF AUSTEMPERED SG IRON		FORGED FABRICATED QUENCH AND TEMPERED		FORGED FABRICATED CONTOUR INDUCTION HARDENED	
	AS 1831-700-2	MAX	AISI 4140	MAX	AS 1831-700-2	MAX	HOFALLOY	MAX	HOFALLOY	MAX
HEAT TREATMENT Hardness	NORMALISED 280 BHN	330 BHN	NORMALISED 280 BHN	360 BHN	AUSTEMPERED 350 BHN	400 BHN	QUENCH & TEMP 330 BHN	380 BHN	INDUCTION HARDENED Core = 280 BHN Case = 50 HRC Depth = 5mm	300 BHN 58 HRC 10mm
QUALITY Machining	AGMA 10 (DIN 7) Hobbed	10	AGMA 10 (DIN 7) Hobbed	10	AGMA 10 (DIN 7) Hobbed	10	AGMA 10 (DIN 7) Hobbed	10	AGMA 10 (DIN 7) Hob/Hardcut	10

EXAMPLE:
Power Details:
Power (kW) 4000
G Speed (RPM) 14



GEOMETRY (Example)	Hofmann Maximum Cap	Hobbing (HSS)		Skiving (Carbide Hob)		Form Milling (Carbide)		Finger Milling + Double Helical	
		External	Internal Gear	External	Internal Gear	External	Internal Gear	External	Internal Gear
Module Mn	25.4	50 Mn	25 Mn	50 Mn	25 Mn	100 Mn	60 Mn	100 Mn	60 Mn
Pressure Ang a	25°	45°	45°	45°	45°	45°	45°	45°	45°
Helix Angle β	5° 30'	45°	45°	45°	45°	45°	45°	45°	45°
Nos Teeth Z	282	700mm	700mm	700mm	700mm	700mm	700mm	700mm	700mm
Face Width F	840	2500mm	500mm	2500mm	500mm	2500mm	600mm	2500mm	600mm
Outside Dia da	7244	14000mm	14000mm	14000mm	14000mm	14000mm	14000mm	14000mm	14000mm
Weight (t) W	50	130t	130t	130t	130t	130t	130t	130t	130t
% PRICE (Example)	100%	115%		135%		120%		140%	
DELIVERY (Example)	36 weeks	36 weeks		34 weeks		16-39 weeks*		20-45 weeks*	
AGMA 6114-B15 Pitting Csf Strength Ks F	1.45 2.04	1.64 2.30		2.86 2.12		2.10 2.56		2.98 3.08	
MECH TESTS Elongation (%) Izod (J)	3 3	6 15		3 10		14 35		14 35	

*Subject to forged steel in-stock availability

LARGE GEAR COMPARISON

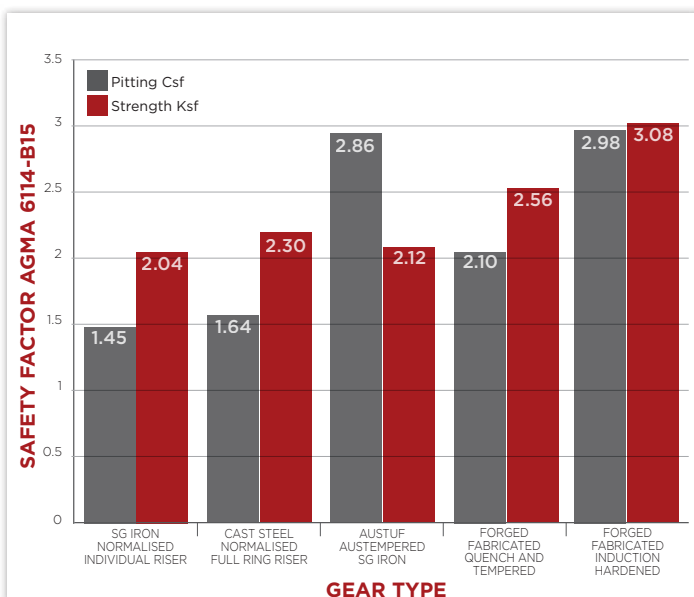

MECHANICAL TEST RESULTS

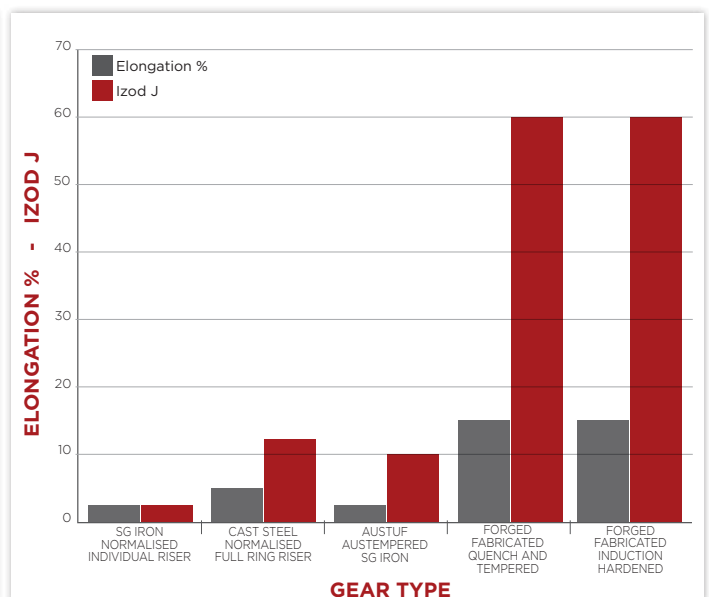

FORGED STEEL FABRICATED GIRTH GEARS



Specialising in high strength forged steel fabricated girth gears up to 15 meters in diameter. This is the manufacturing process producing superior girth gears. The rim steel undergoes a unique manufacturing process to eliminate defects, such as porosities, often found in castings. The steel starts out as a cast ingot and is forged to a third of its original thickness. This ensures a much stronger and more uniform grain structure with no inclusions. The steel is then heated and quenched and tempered to form an extremely tough, tempered, martensitic state yielding high hardness with maximised toughness. Old, worn existing gears with unknown geometry can be easily replaced with a product improved gear. Shipping can be arranged to all continents of the world.

CASTING defects and imperfections cause cracking and tooth breakout.



Forged steel fabricated girth gears overcome cast steel cracking problems. Forged steel gives the highest crack and impact resistance.



HOFALLOY FORGED MATERIAL

Hofalloy 1 forged gear rim material conforms to:

1. AGMA 2001 Grade 2 specification.
2. Typical hardness range 320 - 360 BHN.
3. 3:1 Forging reduction.
4. Hofalloy forged steel gear rim material conforms to AGMA 6114 grade M2 specifications.



INSURANCE SPARE MATERIAL

Hofmann Engineering offers to keep forged Hofalloy plate in stock as an economic insurance measure for customers. One plate of Hofalloy can suit a variety of gears on-site:

1. **FORGED HOFALLOY** plate can be used as an insurance spare to cover many different girth gears.
2. Reduces manufacturing lead time.
3. Lowers insurance premiums.



SITE AUDITS

- Evaluate girth gears and their conditions.
- Determine suitable forged steel rim plate – dimensions based on pitch, face width and gear diameter. Order forged rim plate based on site audit.
- Rim plate can be ordered to suit a variety of gears on-site.



SITE GEAR INSPECTIONS

- Full Dimensional inspections done on-site.
- Diameters, Lengths, Hole PCD.
- Full gear inspection including:
 - Pitch • Lead • Involute
- Hardness testing.
- Crack detection.
- Material chemical analysis.

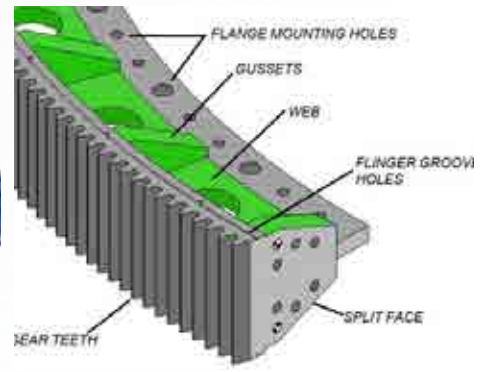

DESIGN

- CAD design with 3D modelling to produce accurate manufacturing drawings.
- FEA analysis to optimise the weld sizing to keep stress levels to a minimum.
- Gear consulting.
- Gear design & rating calculating to DIN & AGMA standards.



FORGED STEEL

- Rim plate can be held in stock until required.
- One plate can be purchased to suit a variety of gears on individual or corporate sites.
- Once forged steel is in stock, manufacture lead time can be significantly reduced.



OXY CUTTING

- The forged steel is marked out & oxy-cut to width to suit the specific gear to be manufactured.
- Purchase of material in advance (no holding fee) allows the spread of costs over a period of time.



BENDING

- The individual lengths of plate are then rolled for the specific radius required for that gear.
- 6000 tonne roll pressing capacity.
- Unlimited length.
- 250mm thick x 3700mm wide.



FABRICATION

- Individual segments are fabricated to the strictest of welding and inspection procedures.
- NDT Inspection including 3rd party NATA ultrasonics.
- Full penetration submerged arc welds on critical joints.
- Stress relieved.



MACHINING

- Proof machined.
- Finished machined.
- Dimensionally inspected to internationally recognised standards.
- Full gear inspection including final mesh testing.



INSTALLATION & ALIGNMENTS

- Experienced team available to plan, manage and install girth gears, pinion assemblies, gearboxes and inching drives.
- Fully equipped with all tooling, for laser aligning, machining, fabrication and mill drive adjustments.

HOFALIGN FORGED STEEL GIRTH GEARS

- HOFALIGN joint design (patent pending) offers superior tooth contact under operational loads by allowing a gussetless gear design to increase the consistency of rim deflection
- 3 - 15m diameters
- Spur, helical and double helical gears
- 100% full penetration welds conforming to ultrasonic, magnetic particle and visual verification
- Standard gussetless gears endorsed by OEM's Thyssenkrupp and Outotec. Also commonly seen on CATERPILLAR/Bucyrus/Marion and P&H dragline hoist gearing

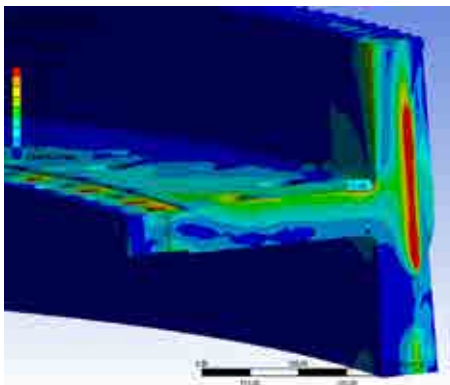

**DESIGN STAGE: FINITE
ELEMENT ANALYSIS (FEA)**



**9M DIAMETER FORGED
FABRICATED GEAR HALF**



**PREPARING FOR
FINAL MACHINING**

HOFALIGN



TOOTH CONTACT DEFLECTION VARIATION AND MAXIMUM PRINCIPAL STRESS

HofAlign gears result in reduced maximum tooth deflection and maximum principal stresses compared with conventional gears. This leads to extended operational life.

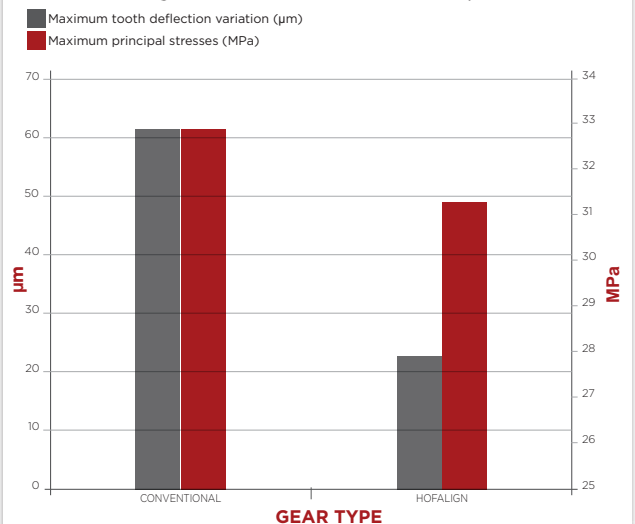

OPEN GEAR RECONDITIONING PROCEDURE



1. WORN GIRTH GEAR

With less than 0.5mm of involute wear.



2. WORN SOFT PINION

With over 5mm of wear.



3. PINION INSTALLATION

Install Hofmann case hardened pinion.

4. APPLY HOFMANN PROCEDURE

1. Measure involute wear on gear.
2. Clean and crack detect gear using magnetic particle method.
3. Install Hofmann case hardened pinion. Case hardness must exceed 55HRC.
4. Laser align drive train.
5. Accurately in situ grind girth gear using the case hardened pinion as a master.
6. Apply Hofmann Lubrication A primer to pinion and gear.
7. Inspect lubrication system and connect running-in lubricant Hofmann Lubrication B
8. Start gear drive slowly increasing the power as the contact improves.
9. Apply repair Force running Lubricant Hofmann Lubrication D to heavy contact areas until good contact is achieved.
10. Monitor and completely document the installation procedure.



5. FINAL GEAR CONTACT



6. FINAL PINION CONTACT



SELECTING OPEN GEAR RECONDITIONING PROCEDURE

GIRTH GEAR

View of open gear showing substantial involute wear.

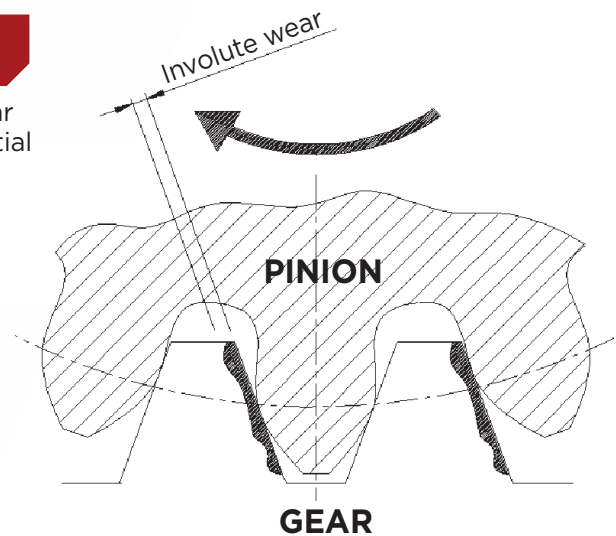

SELECTING GEAR RECONDITIONING PROCEDURE

MEASURE INVOLUTE WEAR ON GEAR THEN SELECT RECONDITIONING PROCEDURE

- Procedure 1:** If involute wear is less than or equal to 0.5mm => In situ grind and chemical etch utilising a Hofmann case hardened pinion.
- Procedure 2:** If involute wear is greater than 0.5mm => Reverse open gear.
- Procedure 3:** If both flanks of the gear are worn => Re-cut the open gear.
- Procedure 4:** If insufficient material is left to re-cut the gear => Replace the open gear.

WARNING!

Do not install a new pinion against a worn open gear unless one of the above procedures (from 1 to 4) has been performed. The new involute form on the pinion would only contact the high points of the worn open gear and this can lead to:

- Extreme vibration and noise
- Severe wear and pitting on both pinion and gear
- High possibility of tooth breakout and destruction of both the pinion and gear

GRINDING MILL SHELLS & HEADS to Ø44ft (13.4m)



- Fabricated steel • Cast SG Iron • Solid stainless steel
- Stainless steel clad • Bimetallic plate

MANUFACTURING CAPACITY:

2 Manufacturing Sites: • Bassendean - Western Australia • Bendigo - Victoria (Australia)

Max Shell Size: Ø13.4m (44ft)

Lift Capacity: 210 tonne (231 ton) x 17m (55.7ft) under crane hook

Vertical Rolls: 6000 tonne (6600 ton) & 4000 tonne (4400 ton)

Sub Arc Welding using tandem head inverter technology

Machining to Ø16m (52ft) x 6m (19.7ft) x 300 tonne (330 ton) capacity rotary table

Floor Borers: 15.3m (50ft) x 5.0m (16ft) & 12m (39ft) x 3.9m (12.8ft)

Heat Treatment: Stress Relieving Ø14m x 4m high

Surface Finish: Abrasive Blast / Paint Booths / Epoxy Coating, Rubber Lining





6000 TONNE VERTICAL ROLLING PRESS

- Thickness (max): 220mm.
- Width (max): 3,650mm.
- Hardness (max): 390 BHN.



FABRICATION

- Typical steel plate to AS3678 Grade 250, EN S235JR, ASTM A36.
- Segments profiled to shape with bevelling.
- Stainless steel clad plate available.
- Plate UT examination to AS 1710.
- Flange plate Z property tensile tested.
- Welded and tested to AWS D1.1.
- Stainless steel to AWS D1.6 available.



VERTICAL BORERS

- BENDIGO:**
- Up to Ø9.22m x 4.45m height 200t.
- BASSENDEAN:**
- Up to Ø8.75m x 2.7m height 200t.



FLOOR BORERS

- BENDIGO:**
- Up to 15.3m x 5.0m high x 1.25m Z travel.
 - Floor plate area 19.50m x 6.55m.
 - Rotary table 2.5m x 2.5m x 200t.



- BASSENDEAN:**
- Up to 12.9m x 3.9m high x 2.0m Z travel.
 - Floor plate area 18.0m x 6.0m.
 - Rotary table.



LARGE VERTICAL MACHINE

- BASSENDEAN & BENDIGO:**
- Floor borer and 200t table to machine and drill mill shells up to Ø15m by 7m height.



GANTRY MACHINING CENTRE

- Unique boom arrangement combined with a rotary table will allow the machine to act as vertical borer and drill on the same set up.
- Max capacity Ø15m.



WELDING MANIPULATOR

- Adjustable to accommodate head angle. Manipulator and boom drives synchronised. 200 tonne capacity. CNC controlled for SS cladding of heads and shells.



ROAD & SEA FREIGHT



ANTONOV AIRFREIGHT TO 90T/PIECE

HEAT TREATMENT

- Stress relieving furnace Ø14m x 4m

SURFACE FINISH

- Abrasive blast, paint, Epoxy coat and rubber line as required.

PACKAGING

- Machined surfaces coated with rust inhibitor. Packaged and protected for road, ocean and air freight.

GEARBOX RANGE

• STANDARD RANGE • SPECIALS



CRUSHING GEARBOXES



CONVEYOR GEARBOXES



CMM INSPECTION



**SHAFT MOUNTED
ALIGNMENT GEARBOXES**



DOUBLE OUTPUT EXTRUDER GEARBOX



**SELF ALIGNING, TWIN PINION
MILL DRIVE GEARBOX**



SELF ALIGNING DRIVES

- Automatically maintains 100% gear contact regardless of movement in foundations and/or driven component.
- Can use recirculating filtered oil.
- Reduced maintenance as alignment checks and adjustments are eliminated.
- Power to 10,000kW per gearbox.



STANDARD GEARBOXES

- Completely designed and manufactured in-house to AGMA, DIN or ISO standards.
- Standard range of multi stage drives.
- Precision case carburised and ground gearing to AGMA 15 (DIN 2) for quiet reliable operation.



SPECIAL GEARBOXES

- Special Gearboxes can be designed to fit existing foundations as a direct replacement of old drives. (Flender, Falk, Valmet etc.).
- Power upgrades, ratio changes and replacement parts available.
- Torque splitting gear drives.



INCHING DRIVES

A range of inching drives to fit new and existing mill and kiln drives. Features include:

- Planetary main reduction.
- Hydraulic or electric.
- Integral or separate brakes.
- Disengaging couplings.



BOGIE DRIVES

- Complete motor, gearbox, coupling assemblies for bogie wheel drives.
- Spiral bevel gear input. These drives are shaft mounted alignment free.



HIGH SPEED PLANETARY

Planetary gearboxes for compact drive solutions. Case carburised gears, precision ground to ensure equal load sharing. Carbo-nitrided internal ring gears. All gearing can be precision ground to AGMA 15 (DIN 2) to ensure quiet, smooth operation.



CONVEYOR DRIVE 3000KW

Conveyor drive gearboxes, shaft mounted or floor mounted. Case carburised and ground gears. SG iron housings or fabricated from mild steel.

Supplied complete with cooling systems and condition monitoring if required.



CENTRIFUGE GEARBOXES

Special purpose gearboxes designed and manufactured to meet the customer's specification. The free floating, inline drive replaces a complex and expensive planetary gearbox.



HIGH SPEED GEARBOXES

High speed drives, speed increasing and speed decreasing, with white metal bearings where appropriate. Gears ground to very high accuracy levels (DIN2/AGMA 15). Units to 50,000kW and 20,000 RPM input speed have been manufactured.

GEARBOX REBUILDS



OLD GEARBOX



UPGRADE EXISTING GEAR DRIVES

- MORE POWER & LONGER LIFE
- QUIETER OPERATION
- LEAKPROOF SEALING
- RE-RATIO



NEW GEARBOX



USING THE LATEST TECHNOLOGY TO OPTIMISE GEARBOXES:

- CASE HARDENED AND GROUND GEARING
- GEAR GEOMETRY OPTIMISATION
- HIGH CAPACITY BEARINGS
- IMPROVED SEALING AND LUBRICATION

AUDITING YOUR GEARBOX REPAIR SHOP

Do they have the equipment and know-how to rebuild your gearboxes?



COMPARE

OTHERS

	<p>GEAR DESIGN</p> <ul style="list-style-type: none"> • Do they have gear design and consulting services? • Do they have a full metallurgical laboratory for carrying out failure analysis? • Are they members of any gear standard association (AGMA, DIN, ISO)? 	<p>?</p>	<p>✓</p>
	<p>GEAR INSPECTION</p> <ul style="list-style-type: none"> • Do they have a certified gear inspection laboratory to inspect gear accuracy? • Can they provide computerised printouts of lead, involute and pitch? 	<p>?</p>	<p>✓</p>
	<p>COORDINATE MEASURING MACHINE</p> <ul style="list-style-type: none"> • Do they have a Coordinate Measuring Machine for checking bore alignment and size of gearbox housings? 	<p>?</p>	<p>✓</p>
	<p>MACHINING/FABRICATION</p> <ul style="list-style-type: none"> • Do they have gear manufacturing facilities for producing improved replacement gearing? • Do they have fabrication facilities for fabricating gearbox housings? 	<p>?</p>	<p>✓</p>
	<p>HEAT TREATMENT</p> <ul style="list-style-type: none"> • Do they have heat treatment facilities for replacement gearing as well as qualified metallurgists? • Do they have carburising, induction hardening, nitriding, quench & tempering, and stress relieving facilities? 	<p>?</p>	<p>✓</p>
	<p>PRECISION GEAR GRINDING</p> <ul style="list-style-type: none"> • Do they have modern, climate controlled gear grinding facilities capable of producing accurate gearing to DIN 2 (AGMA 15)? 	<p>?</p>	<p>✓</p>
	<p>GEARBOX BACK TO BACK LOAD TESTING</p> <ul style="list-style-type: none"> • Do they have a gearbox testbed for load test running gearboxes? • Hofmann Engineering has full gearbox load test facilities to 3,000kW. 	<p>?</p>	<p>✓</p>
	<p>SITE INSTALLATION & SERVICE</p> <ul style="list-style-type: none"> • Do they have site crews trained in gearing to install and laser align gearboxes? • Are they able to provide on-site machining services? 	<p>?</p>	<p>✓</p>

Hofmann Engineering has extensive experience rebuilding gearboxes, small and large, to exacting specifications. If you need your gearbox to run more efficiently Hofmann's can help.

SELF ALIGNING DRIVES

Hofmann Engineering's Self Aligning Drives automatically maintain 100% contact 100% of the time through all loading stages, regardless of:

- Mating gear axial run out
- Foundation movement and temperature expansion changes
- Deflections and load variations

APPLICATIONS

- Mills, kilns, dryers and car dumpers
- Draglines, shovels, winders and slewing drives
- Any gear drive where self aligning is required to reduce maintenance

Case hardened gear couplings to transmit torque.

Hardened spherical bearings to enable self aligning motion.



MILL DRIVES TO 20,000KW

- Using 2 off 10,000kW drives.
- 4 off self aligning pinions drive the girth gear.
- Mechanical drive options to 34MW.



DIRECT MESH GEARBOX

Incorporating twin torque splitting self aligning pinions to 10,000kW.

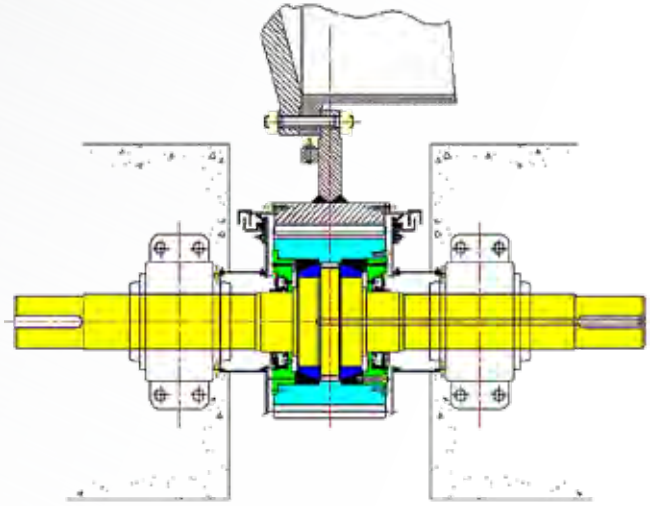

SAP - SELF ALIGNING PINIONS

Conventional Self Aligning Pinion with plummer block bearings.
 • Retrofit to existing mills and drives. • Pinion shaft is reversible.

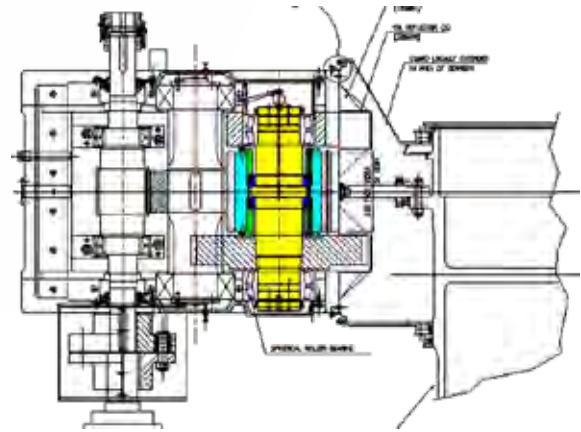
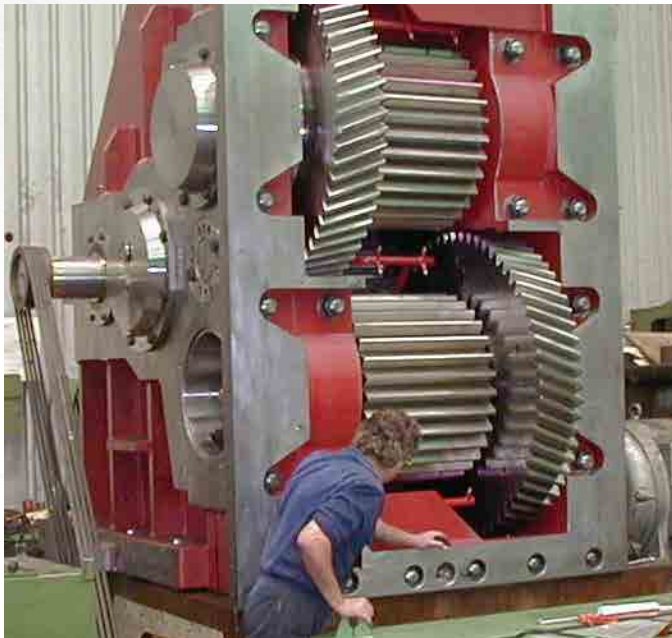

SATP - SELF ALIGNING TWIN PINION DRIVE

• 4 standard sizes - 18Mn, 22Mn, 25.4Mn & 30Mn - that cover the complete range to 10,000kW.
 • Single motor runs two self aligning, torque splitting pinions direct meshed with the girth gear.
 • Reduced foundation, installation and running costs.
 • Oil re-circulating system for gearbox and girth gear.

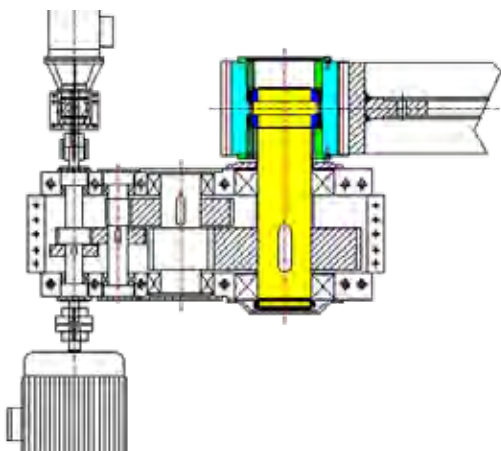

SAOP - SELF ALIGNING OVERHUNG PINION DRIVE

Self aligning overhung pinion mounts directly to output shaft main gearbox.
 • Lowest foundation and installation costs.
 • No low speed coupling or plummer bearings.
 • Split lube system between gearbox and open gearing is now possible.

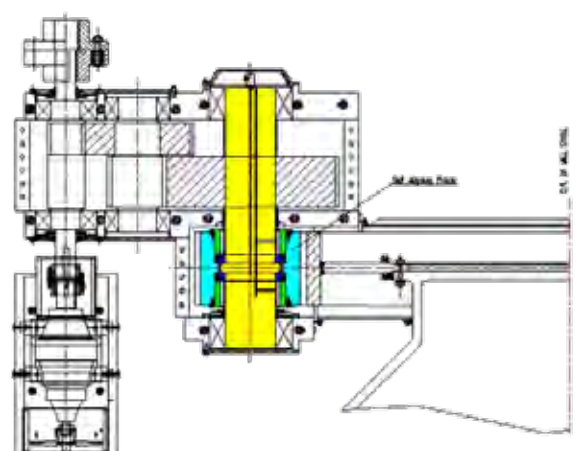

SASP - SELF ALIGNING SINGLE PINION DRIVE

Self aligning pinion mounts directly to the output shaft and is integral with the main gearbox.
 • Reduced foundation and installation costs.
 • No low speed coupling or plummer bearings.
 • Split lube system between gearbox and open gearing is now possible.

BEVEL & WORM GEARING



**SPIRAL •
HELICAL (SKEW) •
STRAIGHT •
ZEROL •
HYPOID •**

also
**WORM WHEELS
& WORM SHAFTS**

CAPACITY:
Size $\leq \phi 4m$

BEVEL GEARING • WORM GEARING

Designed or reverse engineered and manufactured under one roof.

DESIGN

The first step of 5-axis machining is to create a 3D model of the bevel or worm gear. A 3D model to DIN, AGMA or Gleason standards can be created for a new gear using outputs from state-of-the-art engineering calculation programs. For replacement gears, a 3D model of the existing design can be acquired from the CMM and then modified to solve the problem which caused the gear to fail or to optimise future operation. Tooth modification can also be optimised to give quiet running gears.

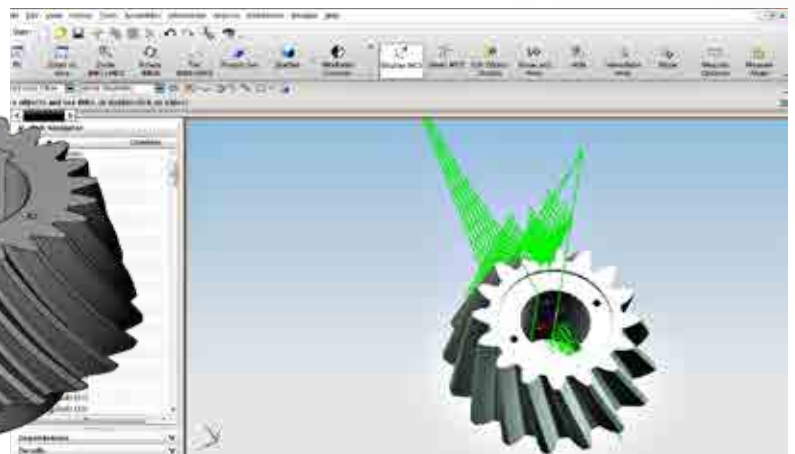

INSPECTION

All gearing must be inspected to ensure that the quality required has been achieved. Specialist Coordinate Measuring Machines are capable of inspecting complicated gearing such as spiral bevel gears, helical bevel gears, worm wheels and worm shafts.

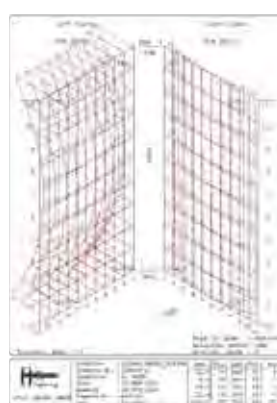

CUTTING



An extensive collection of 5-axis machines to cut spiral, helical and straight bevel gears and worm wheels. Unique software is used to optimise the CAM program for the manufacture of spiral, helical and straight bevel gears and worm wheels.



WORM MESH CONTACT INSPECTION

A mesh test of worm wheel and worm shaft is conducted to confirm contact accuracy.

WORM GRINDING

Worm shafts are ground on form grinding machines to achieve ultimate accuracy and surface finish. After grinding, the gear accuracy is preliminarily checked on the machine prior to final inspection on the CMM and mesh testing if required.



HEAT TREATMENT

Gears up to 1.87m diameter can be case carburised, and gears up to 4m diameter can be full contour, tooth-by-tooth induction hardened.

TESTING

Bevel gears and worm wheels and shafts can be tested in their assembled gearboxes under load to ensure that operational specifications have been achieved.

HPGRs

HIGH PRESSURE GRINDING ROLLS

Driven by a passion to manufacture cutting-edge technology of the highest quality, Hofmann Engineering has established its global position as a reliable supplier of improved and customised HPGR components and services for all major OEMs. Wear components and stud arrangements are tailored to suit ore types, feeds and operating conditions. Hofmann Engineering offers NEW, RESIZED and REFURBISHED "AS NEW" tyres. Cheek plates and other wear components are custom designed to suit specific applications. Hofmann Engineering combines comprehensive engineering knowledge with significant capabilities in detailed design, manufacturing, fabrication and metallurgy to truly be a ONE STOP SHOP for the manufacture of optimised and improved HPGRs. Hofmann's HPGRs aim to reduce downtime and operating costs through the improved service life of all HPGR components.



Tungsten carbide blocks, bolt on retaining clamp plates and soldered Tungsten Carbide pieces (Patent no: 2011301142).

- Individually clamped • Can't break off
- Individual blocks can be replaced.



COMPLETED HPGR ASSEMBLIES LEAVING HOFMANN PERU'S PRECISION MACHINING WORKSHOP IN AREQUIPA



FEED SYSTEMS



PLANETARY GEARBOX DRIVE



CHEEK PLATES

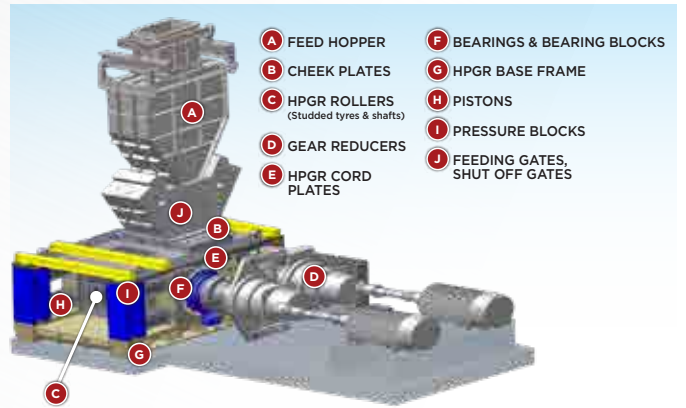

HPGR IMPROVEMENT PARTS

EXTENSIVE WORKSHOP CAPABILITIES

Hofmann Engineering has significant capacity to manufacture and refurbish HPGRs with 200t lifting capacity, 4 stress relieving furnaces and over a dozen vertical and floor borers. Hofmann Engineering also has purpose built submerged arc welding machines, bearing refurbishment capabilities and purpose built stud extraction machines.

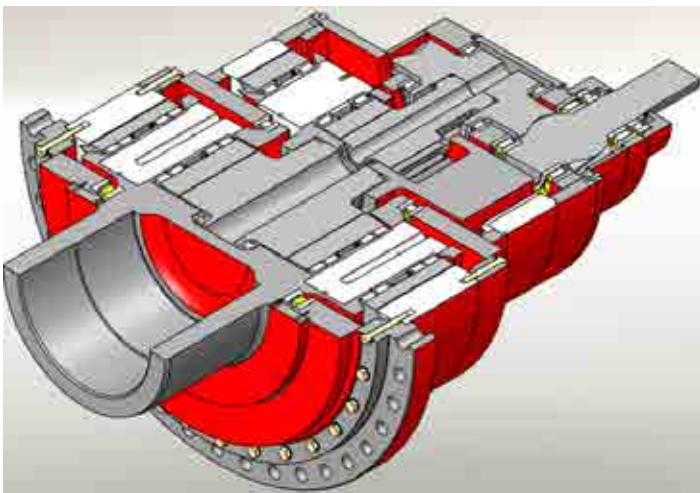

Complete design, new manufacture and refurbishment of **planetary gearboxes** for HPGRs. Component part numbers cross referenced against OEM gearboxes.



Above: Hofmann refurbished P2SA-38 (2800kW) HPGR Gearbox under load test.

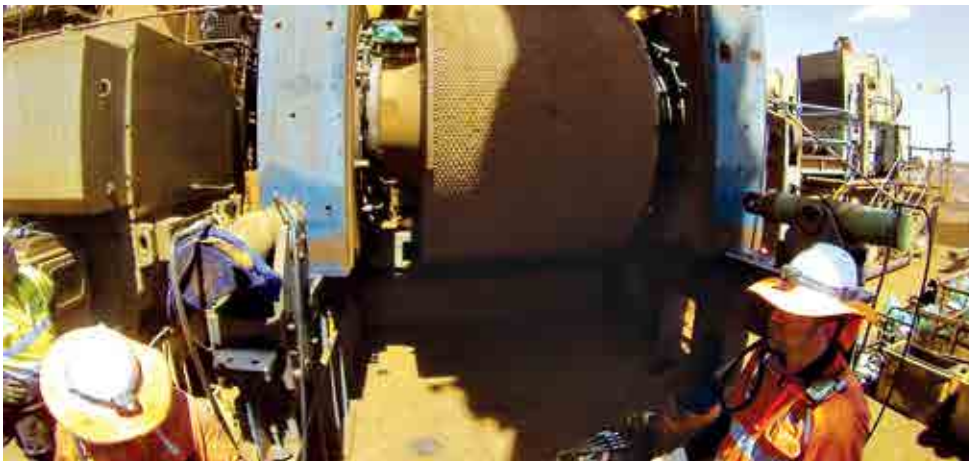

HOFMANN HPGR FIELD SERVICE

The Hofmann HPGR service team provides expertise at all levels to meet customer requirements across the globe. The range of specialist site staff covers all areas, from mechanical installation, to hydraulic and electrical specialists, to complete site supervision assignments. These teams manage complete HPGR installations, gearbox monitoring and refurbishment services, roller changeouts, machine commissioning, complete machine inspections, condition monitoring, in situ repairs and overhauls.

CRUSHER PARTS & SERVICES

• GYRATORY • CONE • JAW • SIZERS • ROLLS

Complete crusher solutions from new supply of cast or forged components to overhaul and refurbishment of worn parts. Extensive fabrication, heat treatment and machining departments can accommodate individual components up to 200 tonnes, allowing for a complete crusher to be manufactured 'under one roof'.



MAIN FRAMES New and refurbished

MINERAL SIZERS



SPIDERS & ANCILLARY COMPONENTS



INTEGRAL MAIN SHAFTS, CORES & MANTLES



JAW CRUSHER COMPONENTS & WEAR LINERS



ROLLS CRUSHERS - HARD FACED, WHITE IRON & SEGMENTED



BEVEL GEARS



CONE CRUSHER HEADS



CRACKED & WORN MAIN SHAFT REPAIRS

Hofmann Engineering can weld repair Crusher Main Shafts that OEMs consider irreparable or where a replacement is not readily available. Hofmann Engineering also manufactures new shafts to suit all types and makes of crushers.



WELD PREPARATION

- Crack is machined out.
- Weld prep machined to generate alignment datums and to suit the sub arc process.



WELD MANAGEMENT

- Hofmann Engineering has in-house welding metallurgists to develop weld procedures for these demanding and challenging jobs.
- Submerged arc welding.



POST HEAT TREATMENT

On completion of welding, the entire shaft is stress relieved in a purpose-built oven that allows the shaft to be rotating throughout the process.

COMPONENT REBUILDS: LOCKING & ADJUSTMENT RINGS, HEADS & BOWLS



WELDING

All weld repairs are monitored throughout the process. This allows Hofmann Engineering to fully endorse challenging repairs, such as cracked or broken adjustment rings.



MACHINING

All items are finish machined to OEM specifications. Threads are machined using a 5-axis vertical borer to ensure pitching accuracy.



ASSEMBLY

Components can be partially or fully assembled to reduce downtime during component changeouts.

WORKSHOP & SITE SERVICES PROVIDING MINE SITES WITH THE COMPLETE PACKAGE



SUPPLY OF BEVEL GEARS

- Supplied to AGMA 10 quality, either:
- Quench & tempered to 360 BHN.
 - Induction Hardened to 56 HRC.
 - Case Carburised to 60 HRC.



SPECIAL REQUIREMENTS

Hofmann Engineering will develop and manufacture special crushers to meet specific product or customise existing equipment to suit specific needs.



SITE & BREAKDOWN SERVICE

Experienced Site Services team for installation, site inspections and commissioning for planned or unforeseen shut downs.

FULLY FORGED CRUSHER HEADS

• METSO • FLSMIDTH • SANDVIK

WORLD'S FIRST!

Hofmann Engineering is constantly working on pushing the boundaries of existing knowledge and best engineering practice. With a focus on continuous improvement, Hofmann Engineering has developed the world's first fully forged crusher head. The advantages of using a forging over a casting are:

- Improved internal microstructure
- Grain refinement resulting in higher toughness compared to cast heads
- 100% of surfaces are machined and therefore are free of surface defects or poor surface finishes typically exhibited in cast heads
- Forgings are free of weld repairs (frequent crack initiation point on cast heads)

The internal 'kidney' area of Hofmann's forged heads undergo polishing followed by shot-peening to induce residual compressive stress in this region which dramatically improves the fatigue life of the head.



APRON FEEDER PARTS & SERVICES

AUSTRALIAN MANUFACTURED ALTERNATIVES TO:

- Fabricated or cast manganese feeder pans
- Sprockets (product improved option: induction hardened segments).
- Manufactured complete drive shafts and idlers
- Chains and wear plates.



PICTURED ABOVE: Hofmann's latest M100 5-axis multifunctional CNC lathe machining a complete apron feeder drive shaft.

The M100 is capable of:

- Turning • Drilling • Milling • CAM Milling
- Circular milling • 5-axis Milling • Gear hobbing



A complete range of manufactured and refurbished Apron Feeder components are available. Components include pan flights, rollers/idlers, impact bars and drive shaft/tail assemblies. Extensive industry knowledge and experience complements a commitment to deliver high quality products and services to customers.

HOFNUTS

THE HIGH TENSION BOLTING SOLUTION



TYPICAL APPLICATIONS:

- Girth gear split lines
- Gearbox split lines
- Pressure vessels
- Hold-down bolts
- Engine bolts

HOFNUTS ENABLE YOU TO:

- Tighten large nuts with hand wrenches
- Tighten split joints accurately to the correct tension
- Minimal space requirements

REMOVES THE NEED TO USE:

- Hydraulic tensioning
- Crane wrenches
- Other cumbersome methods of tightening

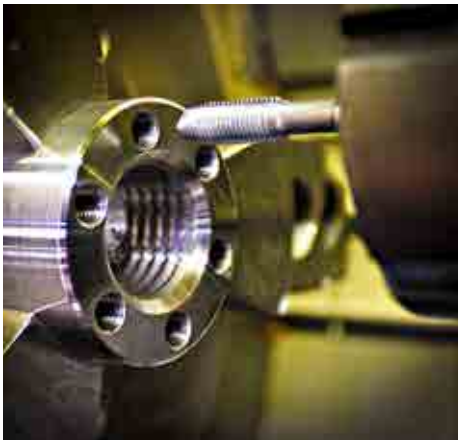

STOCKED BLANKS

FOR QUICK DELIVERY

Hofmann Engineering hold in stock a range of pre-machined billets to minimise lead time in the production of a customer's specific requirements. These blanks can accommodate any size and/or pitch between 30mm and 80mm and are available in both grades.



GRADE HSN 41

STANDARD

The HSN 41 HofNuts are used for general mechanical applications. These nuts are standard on the split lines of our girth gears, and commonly used on newly manufactured and refurbished gearboxes. A range of sizes are kept in stock for quick delivery.



GRADE HSN 43

HIGH TENSION

For high tension applications, we recommend our HSN 43 grade HofNuts, which are manufactured from a higher grade of steel and contain more jacking bolts. The 43 series can apply up to 50% more force to a split line when used with an appropriately rated bolt.

BOLTING LUBRICATION

For ease of lubrication, each set of HofNuts comes with a tube of 46MR401 lubricant for use on the jacking bolt threads and between the tips and the washer.

MISALIGNMENT SOLUTIONS

SPHERICAL SEATS

Have a misaligned bolting face? The use of spherical seats allows the tensioning of bolts that may be out of alignment, ensuring that your equipment remains tensioned securely. The spherical seats can withstand more than twice the force that can be exerted by a fully tensioned HofNut and still maintain their original structural integrity.

JACKING BOLT dia.	TORQ. NM		PRELOAD kN	
	Std	Max	Std	Max
6.00	14.00	21.00	18.15	27.25
8.00	34.00	50.00	33.10	48.70
10.00	67.00	100.00	52.20	77.85
12.00	128.00	179.00	84.65	118.37
16.00	320.00	424.00	160.24	212.32
20.00	661.00	876.00	269.46	357.11



HOFNUT STANDARD LOAD HSN 41 SERIES

NOMINAL	A	B	C	D	E	F	G	N	THREAD SIZE OF JB	H	TORQ. NM		PRELOAD kN	
											Std	Max	Std	Max
M30x3.5	53	24	53	5	45.0	40	29.0	6	M8x1.0P	6	34	50	199	292
M36x4.0	66	32	66	5	57.0	52	37.0	6	M10x1.25P	8	67	100	313	467
M42x4.5	75	32	75	5	57.0	52	37.0	8	M10x1.25P	8	67	100	418	623
M48x5.0	85	38	85	6.5	68.5	62	44.5	8	M12x1.25P	10	128	179	677	947
M56x5.5	100	38	100	6.5	68.5	62	44.5	8	M12x1.25P	10	128	179	677	947
M64x6.0	113	53	113	8	92.0	84	61.0	8	M16x1.5P	14	320	424	1282	1699
M72x6.0	119	56	119	8	92.0	84	64.0	8	M16x1.5P	14	320	424	1282	1699
M80x6.0	132	56	132	8	92.0	84	64.0	12	M16x1.5P	14	320	424	1923	2548
M90x6.0	145	58	145	8	99.0	91	66.0	16	M16x1.5P	14	320	424	2564	3397
1½"UNCx6TPI	64	30	64	5	57.0	52	35.0	6	M10x1.25P	8	67	100	313	467
1½"UNCx6TPI	69	32	69	5	57.0	52	37.0	8	M10x1.25P	8	67	100	418	623
1¼"UNCx5TPI	78	36	78	6	68.0	62	46.0	8	M12x1.25P	10	128	179	677	947
2"UNCx4.5TPI	90	40	90	6	68.0	62	46.0	8	M12x1.25P	10	128	179	677	947
2¼UNCx4.5TPI	100	38	100	6	58.0	52	44.0	8	M12x1.25P	10	128	179	677	947
2½"UNCx4.0TPI	113	53	113	8	92.0	84	61.0	8	M16x1.5P	14	320	424	1282	1699
2¾"UNCx4.0TPI	119	53	119	8	92.0	84	61.0	8	M16x1.5P	14	320	424	1282	1699
3"UNCx4.0TPI	132	53	132	8	92.0	84	61.0	12	M16x1.5P	14	320	424	1923	2548

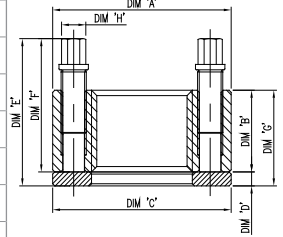

HOFNUT HI-LOAD HSN 43 SERIES

NOMINAL	A	B	C	D	E	F	G	N	THREAD SIZE OF JB	H	TORQ. NM		PRELOAD kN	
											Std	Max	Std	Max
M30x3.5	53	24	53	5	45.0	40	29.0	8	M8x1.0P	6	34	50	265	390
M36x4.0	66	32	66	5	57.0	52	37.0	8	M10x1.25P	8	67	100	418	623
M42x4.5	75	32	75	5	57.0	52	37.0	12	M10x1.25P	8	67	100	626	934
M48x5.0	85	38	85	6.5	68.5	62	44.5	10	M12x1.25P	10	128	179	847	1184
M56x5.5	100	38	100	6.5	68.5	62	44.5	12	M12x1.25P	10	128	179	1016	1420
M64x6.0	113	58	113	8	92.0	84	61.0	10	M16x1.5P	14	320	424	1602	2123
M72x6.0	119	58	119	8	92.0	84	61.0	12	M16x1.5P	14	320	424	1923	2548
M80x6.0	132	61	132	8	92.0	84	69.0	16	M16x1.5P	14	320	424	2564	3397
M90x6.0	145	61	145	8	99.0	91	69.0	16	M16x1.5P	14	320	424	2564	3397
1½"UNCx6TPI	64	30	64	5	57.0	52	35.0	8	M10x1.25P	8	67	100	418	623
1½"UNCx6TPI	69	32	69	5	57.0	52	37.0	8	M10x1.25P	8	67	100	418	623
1¼"UNCx5TPI	78	36	78	6	68.0	62	46.0	12	M12x1.25P	10	128	179	1016	1420
2"UNCx4.5TPI	90	40	90	6	68.0	62	46.0	12	M12x1.25P	10	128	179	1016	1420
2¼UNCx4.5TPI	100	38	100	6	58.0	52	44.0	12	M12x1.25P	10	128	179	1016	1420
2½"UNCx4.0TPI	113	53	113	8	92.0	84	61.0	12	M16x1.5P	14	320	424	1923	2548
2¾"UNCx6TPI	119	53	119	8	92.0	84	61.0	12	M16x1.5P	14	320	424	1923	2548
3"UNCx4.0TPI	132	53	132	8	92.0	84	61.0	12	M16x1.5P	14	320	424	1923	2548

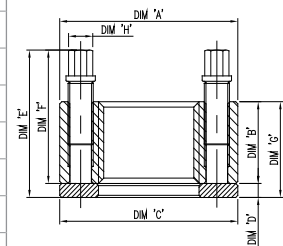

N = NO JACKING BOLTS

$$\text{REQUIRED JACKING BOLT TORQUE} = \frac{\text{REQUIRED PRELOAD} \times \text{STANDARD JACKING BOLT TORQUE}}{\text{STANDARD PRELOAD}}$$

VACUUM DISC FILTERS



Hofmann Engineering has extensive experience in the manufacture and refurbishment of disc filter parts and complete assemblies.

- Vacuum filter including filter discs, filter barrel with bearings and seals, control valve assembly with control and wear plates, automatic dump valve, filter trough, disc outer rim guide, filter media and emergency overflow.
- Surface preparation, priming and painting of equipment, shop assembly, inspection and testing.



COARSE & FINE SEED DISC FILTER MANUFACTURE

to the design of:

- Bokela • Poseidon

CURRENT END USERS:

- Alcan Gove
- Alcoa Australia
- Worsley Alumina
- Guinea
- BMA (Saraji)
- Nalco (India)

SUPPLY OF SPARE PARTS FOR ALL MAKES:

- Disc sectors
- Barrels
- Control heads
- Bearing housings
- Gearboxes
- Agitators



WELDING/FABRICATION

Close supervision ensures accuracy of the fabrication. Weld procedures and welding processes are managed by our experienced team.



INLINE TESTING

NDT testing of welds, dimensional inspections and leak tests carried out at various stages during the manufacturing process.



SURFACE TREATMENT

Strict adherence to sand blasting and painting procedures to ensure surface treatment will withstand the on-site environment.



MACHINING

All machining is able to be carried out in-house using a variety of conventional and modern NC machines.



INSPECTION

All components are inspected during and after the manufacturing process. Critical components are jig tested for compliance.



PRESSURE PARTS

Manufacture of all pressure parts is to the specified Australian Standard and relevant welding codes.



ASSEMBLY

All filters are assembled and dry run. Bearing clearances, axial and radial run outs along with disc sector clearances are checked as part of this process.



CAPACITY

Hofmann Engineering has a number of large assembly bays where this type of work can be carried out. This allows more than 1 unit to be worked on at a time.



PACKING

The filter components are packed for transportation either on flat racks, containers or directly onto prime movers. All machined surfaces are protected and a heavy emphasis is placed on securing the items for sea freight.

VALVES & PUMPS

- Hofmann Angle Slurry Valves
- Manual valves fitted with power devices to remove hammering and injury to operators
- High chrome products
- Replacement pump parts
- New remote valves reduces operators exposure to hazards



HOFMANN ANGLE ISOLATION VALVES IN OPERATION

Remote "Air" operated system to open/close and isolate slurry angle valves. This proven system has a safety and ergonomic advantage by removing operators from hazardous areas. It can operate multiple valves simultaneously from a control box. Easy and safe to operate.



DRAIN VALVES MADE EASY TO OPERATE

Power operating device fitted to a manual valve can be operated using a suitable torque multiplier. Valves can be opened and closed from 2 directions, making the operation of valves facing the ground easy. Through advanced gearing it produces three times input torque to open and break through built up scale. Fully tested and patented product.



ASSEMBLY

Slurry valves fully manufactured, assembled and hydrostatically tested for local and international alumina refineries for over 35 years.



FLEXIBILITY

Multi-site operations, machining capacities and experienced teams allows immediate scale up from single product manufacture to high volume production of valves.



GLOBAL REACH

The logistics team looks after applicable packing requirements and arranges the preferred mode of transport to any destination worldwide.



HIGH CHROME IRON PUMP REPLACEMENT PARTS: 27% TO 35% CR (60 HRC HARDNESS)

Manufactures and product improves standard parts to suit individual site applications. Product improvements are carried out in conjunction with site reports and details of the application. Threads are machined in the hardened parent material.



HIGH CHROME IRON VALVES

Fabricated valve bodies with 27% Cr liners

SPOOLS

Fabricated spools with high chrome iron liners.



CERAMIC LINED VALVES



CHECK VALVES

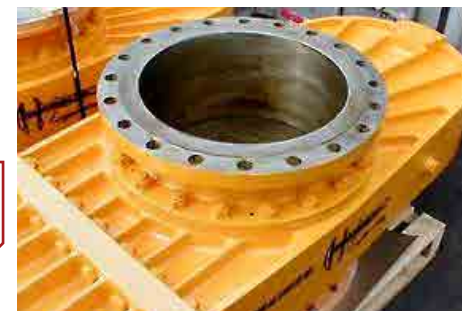

SPECTACLE GATE VALVES (CL150)

- Hydraulic operated valves.
- Sizes from 250NB to 650NB.

WINDER COMPONENTS

• UNDERGROUND MINING

SHAFT & INCLINED HOISTING SYSTEMS

- SHAFTS
- HOISTS
- DRUMS

A 'one-stop-shop' for all winder drum components.



**CLUTCH DEVICE
SLIDING RING**



FIXED DRUM



COIL SLEEVES

A large number of CNC machines that can easily machine not only rope grooves but even the most complex of designs to suit your needs.



MAIN SHAFT

The largest horizontal CNC lathe in the southern hemisphere, capable of machining shafts up to 35 metres long.

Highly skilled and professional fabrication workers and a number of high precision machines, ensure that winder control drums are manufactured to the highest quality.

CAPABILITIES: Hofmann Engineering has a large number of machines across 6 different manufacturing sites.



VERTICAL PLATE ROLLS

VERTICAL BORERS MACHINING UP TO Ø15M DIA.

A number of large vertical borers with capacity up to Ø9.2m x 4.45m height and 200t to accurately machine winder drums. The machines are fitted with precision digital readouts on all axes.

A range of vertical plate rolls with capacity up to 6,000 tonne x 3,200mm wide for any diameter. These rolls are used for rolling winder control drum segments as well as mill shells and kiln sections.



LARGE CNC LATHES

- CNC Lathes up to 35m long
- A number of large high precision CNC lathes for machining winder shafts.
- With capacity of Ø1,900mm dia. swing x 35m long x 50T with steadies.

1960'S BENDIGO ORDINANCE FACTORY FINISHED WINDER CONTROL DRUM



VIBRATING SCREENS

A globally recognised engineering service provider offering complete screening solutions to the mining industry. Design, manufacture and refurbishment of screen, pan and grizzly feeders, and all types of exciter gearboxes is offered.

REPLACEMENT PARTS & SERVICE

to suit OEM exciter gearboxes

- Schenck •
- Metso •
- Ludowici •
- Joest •
- Thyssen Krupp •



PRODUCT IMPROVEMENTS

EXCITER GEARING: Hofmann Engineering manufactures superior case hardened and ground gears to AGMA 10 (DIN 7) to replace the original through hardened gears in the exciter gearbox. The higher quality and harder gearing increases service life and reduces the build up of metal contaminants.

SCHENCK SLD 4385 EXCITER MOUNTING BEAM: Re-engineered exciter mounting beam with the following design improvements:

- Galvanised/painted with rubber coating
- Improved material properties
- Long cycle stress relief
- Welds dressed & shot-peened

Design improvements to the exciter beam remove potential crack initiation points to improve crack resistance of the beam, leading to extended service life and reduced plant downtime.



JOEST JR-606 EXCITER GEARBOX

Complete upgrade of exciter gearboxes to fully re-engineered and improved parts are available to increase service life.



LUDOWICI LE150 EXCITER GEARBOX

Complete refurbishments of Ludowici exciter gearboxes are available.



FULL LOAD TESTBED

Exciter gearboxes can be tested under full load after final assembly. Vibration analysis, temperature readings and oil samples are conducted to assess the gearboxes operation.

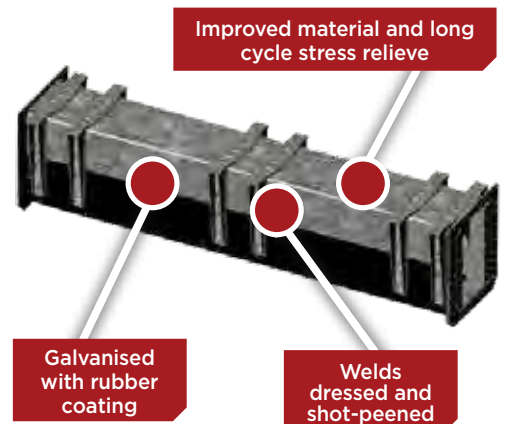

UNDERGROUND MINING PARTS & SERVICES

• CATERPILLAR • JOY GLOBAL • ATLAS COPCO • SANDVIK

Superior product improved parts that are completely interchangeable to OEM parts for underground mining loaders. New parts and repairs are offered. Hofmann Engineering understands the extremely high safety and reliability requirements expected of underground replacement parts. It ensures that every part manufactured has undergone thorough quality control and that the latest engineering technology is applied to improve service life expectations.

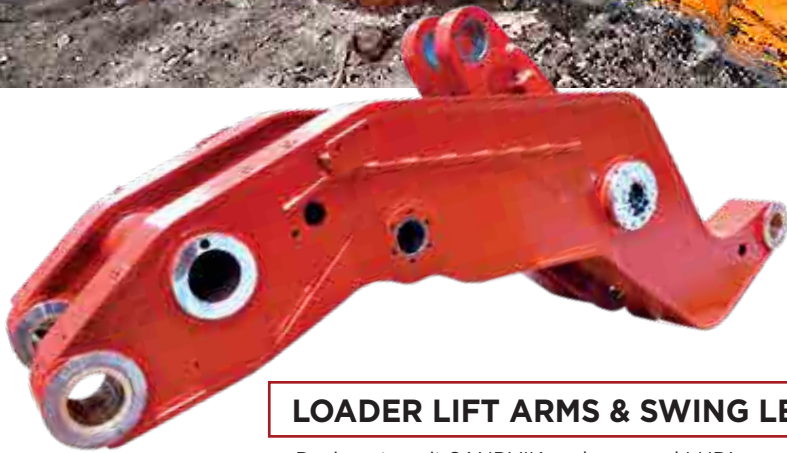

LOADER LIFT ARMS & SWING LEVERS

- Designs to suit SANDVIK underground LHD's.
- Supplied with bushes installed.



CRAWLER PADS

- Forged construction.
- Optional induction hardening available to suit tougher ore conditions.



CONVEYOR LINKS

- Various pitch lengths to suit
- Product improvement: upgraded heavier pins for longer service life.



DRIVE SPROCKETS

- 'HofCarb' case hardening for sprockets to a hardness of 60-62HRC. The process introduces carbide molecules into the martensitic microstructure to increase wear resistance and reduce surface fatigue.
- Upgraded 18CrNiMo7-6 material used.



QUILL SHAFTS

- Upgraded material used.
- Both spline ends are induction hardened to improve torsional fatigue resistance.



CUTTER DRUMS AND PICKS

- New or repaired units.
- Upgraded picks to improve bonding between carbide and steel.

DRAGLINE PARTS & SERVICES

• CATERPILLAR/BUCYRUS/MARION • KOMATSU/P & H • UDD

With a long engineering and manufacturing background in dragline components, Hofmann Engineering supply the full range of new and refurbished dragline parts that are interchangeable with the OEM's. All major mechanical components are available including the swing base, rack, rails and rollers, walking eccentrics, cams, shafts, gearboxes and boom point sheaves. In situ induction hardening of rope drums by Hofmann's Site Team reduces downtime.



SWING RACK ASSEMBLIES

- Forged alloy steel rack rims Q&T to 330BHN combined with fabricated construction.
- High performance racks with a unique heat treatment procedure that increases the hardness to 450BHN.
- Swing pinions are full contour induction hardened.



UDD MECHANICAL CONVERSIONS

Hofmann Engineering completely designed, manufactured and installed the mechanical drive for the UDD (Universal Dig and Dump) dragline.

Our concept provides a free-floating, alignment free, shaft mounted, modular gearbox that bolts to the side of the rope drum. This gearbox contains HofCarb carburised and precision ground gearing with a filtered oil recirculation system.

Being shaft mounted and modular enables this gearbox to be pre-test run and changed out in under one shift without requiring realignment.



INPUT MOTOR PINIONS

- Double helical hard cut narrow gap. Case carburised to 60-62HRC and finished to AGMA 12 quality.
- Quench and tempered to 360 BHN and cut to AGMA 10 quality as per OEM design.
- CARB bearing alignment technology with eccentric cartridges can also be used on Bucyrus machines to give over a 200% improvement in bearing life.



RAILS & ROLLER ASSEMBLY

- Original or 3rd (thrust) rail designs.
- Laser tracking inspection to 40 micron accuracy.

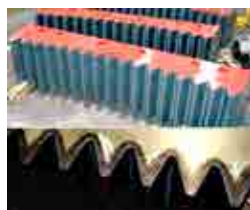

RACK SEGMENTS

- Fully assembled and inspected in-house prior to on-site installation.

RACKS, RAILS & ROLLERS

- Improved material chemistry to achieve increased hardness and superior mechanical properties.
- High quality forgings fully ultrasonically tested to AS1065 Level 1.
- Complete assemblies trial fitted prior to despatch.

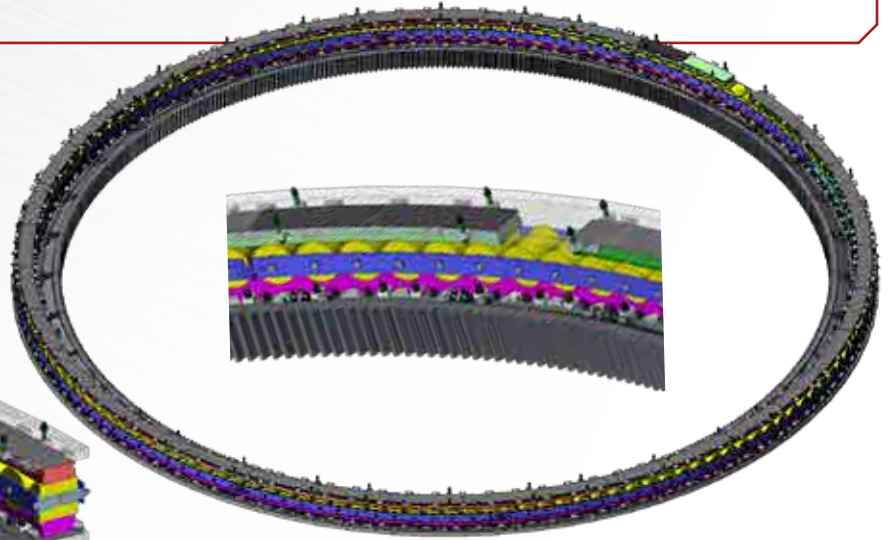
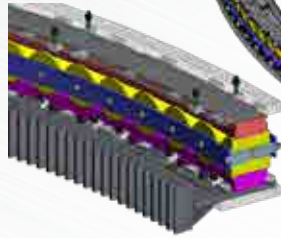

PROPEL ECCENTRICS



1. FORGED

- A single piece quench and tempered forging results in superior mechanical properties.
- Hardness achieved: 320-350 BHN.

2. FORGED FABRICATED

- Eccentric casting fully machined.
- Forged steel version available from AS1444-4330 steel.
- Hardness achieved: 270-300 BHN.

3. CAST VERSION

- Eccentrics also available as an original cast version.
- Hardness achieved: 220-260 BHN.

4. FULL REFURBISHMENT

- Welding, stress relieving and machining back to as new dimension including the spline.

SWING BASE TUBS



- Manufactured with a minimum of 80mm plate for the circumferential diaphragm sections.
- Stress relieving is carried out on the full tub quadrant sections.
- Supplied in 5 major fabricated sections for ease of site assembly with minimal site installation time required.
- Includes general thickening of bulkhead diaphragms.
- Includes 2 pinion change-out holes (with covers and lower support structures.)

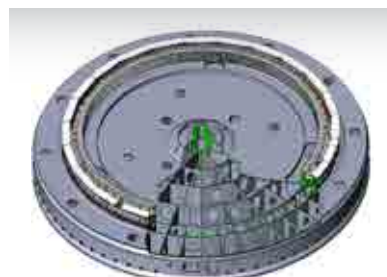



DRUM GEARS

- New forged steel gears 330 to 360 BHN precision cut to AGMA 10.
- Mechanically re-rimmed gears: Replace the gear teeth with a bolt on arrangement to save time and money.
- Re-rimmed gears: Remove old rim and weld new rim to hub with submerged arc full penetration weld.



INTERMEDIATE ASSEMBLY

- Intermediate gears: forged steel, staggered tooth, double helical, through hardened 330 to 360BHN, precision cut to AGMA 10 quality.
- Intermediate shafts: forged steel, spline coupling carburised to 60-62HRC, precision cut to AGMA 12 quality.
- CARB bearings increase bearing life by up to 200%.

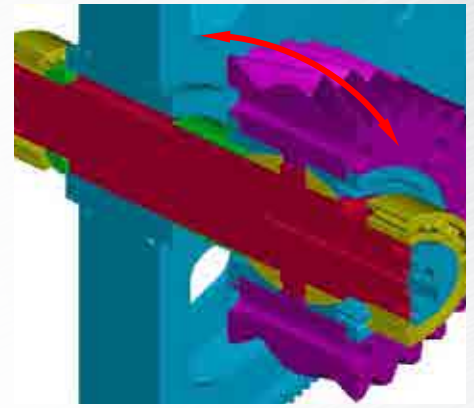

SELF ALIGNING PINIONS

- Self-aligning gearing technology maintains 100% contact in operation.
- Double helical zero-gap 19" face width, carburized to 60-62HRC and precision ground to AGMA 12 quality.
- Spherical bearings carburised to 60-62HRC and lapped for 100% contact, oil lubricated.



PROPEL GEARS

- New or reclaimed hub.
- Reversible gear rim on the same side hub thus doubling the life of the gear.
- Mechanically fastened rim can be replaced independently of hub.
- Forged steel gear rim, through hardened gear 330 to 360BHN, precision cut to AGMA 10.



PROPEL SHAFTS

- New shafts of high quality alloy forging with a higher forging reduction.
- Quench and tempered to achieve hardness of 320-360 BHN.
- Polished and shot-peened radii and transitional areas to increase strength.



SWING PINIONS

- Forged High Alloy steel precision ground to AGMA12.
- Induction hardened full contour induction hardened to 54-58HRC 8mm thick case.
- Impact resistant core hardness of 280-310BHN.



ROPE SHEAVES

- New forged steel rope sheaves, full contour induction hardened grooves to 55HRC for a case depth of 6mm.
- Repaired sheaves by full penetration submerge arc welding the worn groove and then induction hardening.



8200 HOIST ARRANGEMENT

- Modular design allows quick and easy change out.
- Rigid construction reduces distortion and gear misalignment.
- Interchangeability between gearboxes and gearing.
- Self-aligning technology maintains 100% contact during floor deflection.



GEARBOX MODULE

- Maintenance and testing of gearbox can be done in a clean workshop rather than inside the dragline.
- Installation requires less skill and accuracy with the self aligning pinion.
- Gearing: forged steel, carburised to 60 ± 2 HRC, high precision ground.



SHAFT MOUNTED GEARBOX

- Modular design allows quick and easy change out in one shift.
- Rigid construction reduces distortion and gear misalignment.
- Free floating isolated from dragline floor distortion.
- Alignment free gearbox bolts directly to the hoist drum.



SWING PLANETARY

- The swing gears are manufactured from high quality alloy steel forgings and heat treated to increase load carrying capacities.
- All gearing is ground to high AGMA quality.

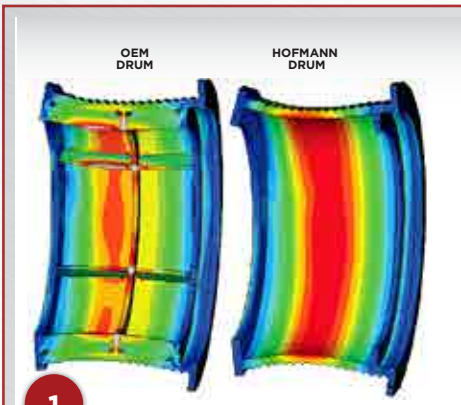

1 ROPE DRUM DESIGN

- Finite element analysis to eliminate the tendency of OEM rope drum internal stiffeners to crack.
- Hofmann Engineering design removes all internal lateral stiffeners and increases the drum shell forging thickness to reduce stress.



2 ROPE DRUM MACHINING

- All rope drums are fully machined in-house from the initial fabrication preparations right through to cutting of the rope grooves, turning of the flanges and drilling and tapping of the holes. This ensures that complete control of the project is maintained and the highest standards of quality are guaranteed.



3 INDUCTION HARDENING

- New forged steel drums: fully fabricated using full penetration welds and then full contour induction hardened to 55 HRC for a case depth of 6mm.
- Worn drums: all cracks are removed before the drum is built up with 30mm of submerged arc weld, machined and then induction hardened.



4 ROPE DRUM CLAMPS

- Unique design developed by Hofmann Engineering.
- Clamp is integrated into the rope drum center flange.
- Precision machined.
- Case hardened.
- Optimized for weight.
- Greater clamping force.



CENTRE PINTLE

- Designed using FEA modeling to reduce the magnitude of stress and reduce stress concentrations.
- New forged steel construction overcomes cast steel cracking problems.



HOIST/DRA G BULL GEARS

- New forged steel 3 piece design.
- The spider is an AISI 1444/4140 quench and tempered forging with a hardness range of 280-320 BHN instead of a casting.
- The gear rim forging is AISI 1444/4330 quench and tempered with hardness of 320-360 BHN. This forging offers better mechanical properties to go along with the increased hardness.
- Depending on customer preference, can be supplied in parts or as an assembly.

ELECTRIC ROPE SHOVEL

PARTS & SERVICES

• CATERPILLAR/BUCYRUS/MARION • KOMATSU/P&H

Hofmann Engineering offers a wide range of replacement parts for Electric Rope Shovels which are interchangeable with parts from Caterpillar (Bucyrus/Marion) & Komatsu (P&H). Major components include: dipper handles, all transmission (hoist, crowd, swing & propel), complete undercarriages, swing racks, swing shafts, propel shafts, boom sheaves, rope drums & padlocks.



CATERPILLAR/BUCYRUS PLANETARY GEARBOXES

- Product improved Hoist, Swing, Crowd and Propel for 495BI/BII/HR/HF/HD.
- New, overhauled or service exchange gearboxes.
- Like for like replacement internal gearing, or upgraded to latest technology of case hardening by carburising or induction hardening & precision form grinding to AGMA 12 (min).
- Full gear quality inspection to AGMA or ISO of all gearing using the latest gear testing technology.
- Test run prior to despatch.



KOMATSU/P&H PLANETARY GEARBOXES

- Product improved Swing and Propel gearboxes to suit all 2800 XPB/XPC and 4100 A/C/XPB/ XPC machines.
- New, overhauled or service exchange.
- Upgraded, carburised and precision ground internal gearing complying to AGMA 12 (min).
- Full gear quality inspection to AGMA or ISO of all gearing using the latest gear testing technology.
- Test run prior to despatch.



ROPE DRUMS & GEARS

- Forged alloy steel rope drums
- Full contour induction hardened rope grooves.
- New, refurbished or service exchange.
- Forged alloy steel drum gears.
- Induction hardened precision ground or hard cut gear teeth.

ELECTRIC ROPE SHOVEL

PARTS & SERVICES

• CATERPILLAR/BUCYRUS/MARION • KOMATSU/P&H

HOFMANN BOLTED SPLIT LINE DESIGN

The solution to split line tooth cracking for Komatsu/P&H shovels.

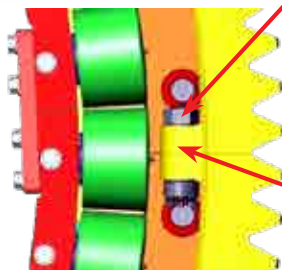
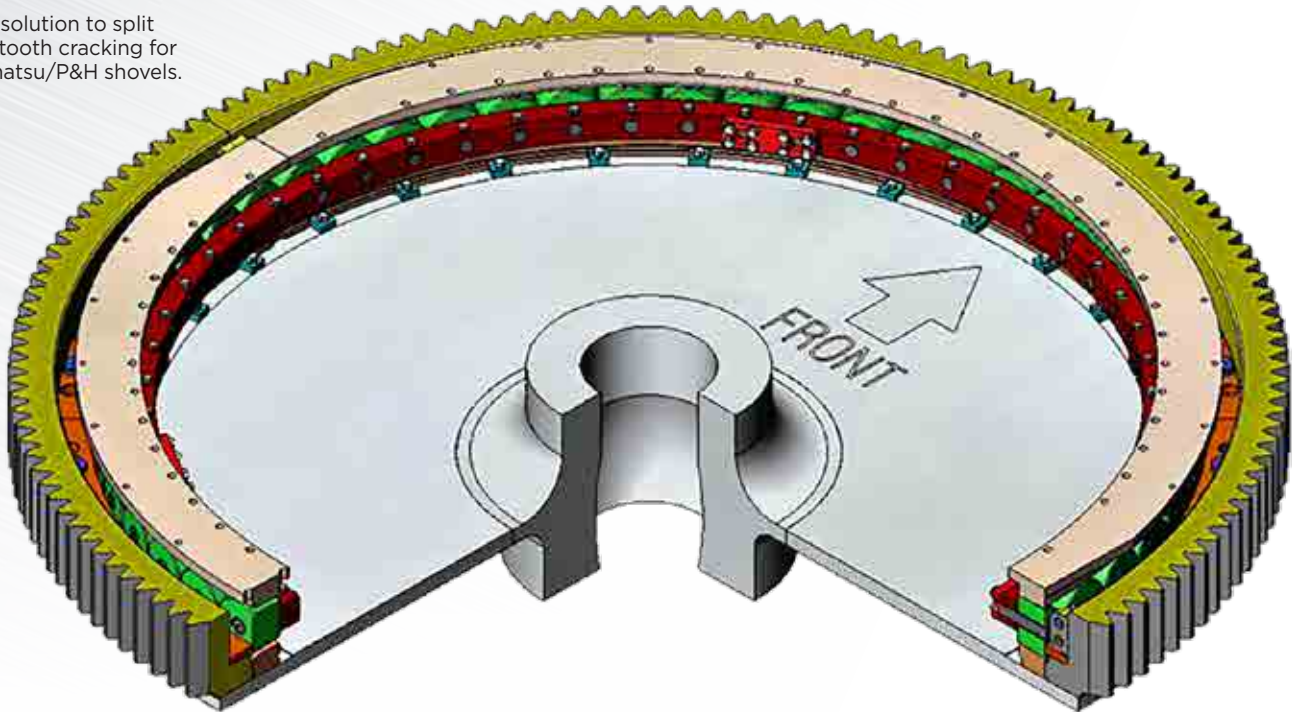

2 Fitted Dowel Bolts with Hofnuts secure the split line with 190T of clamping force.

Tapered joint face and Hofnuts prevent tangential separation force and hence fatigue cracking.

Fitted bolting sleeve also helps retain the split joint.

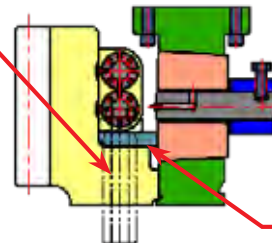

Replaceable thrust rail.

NEW IMPROVED SWING RACK FOR 7495 SHOVELS

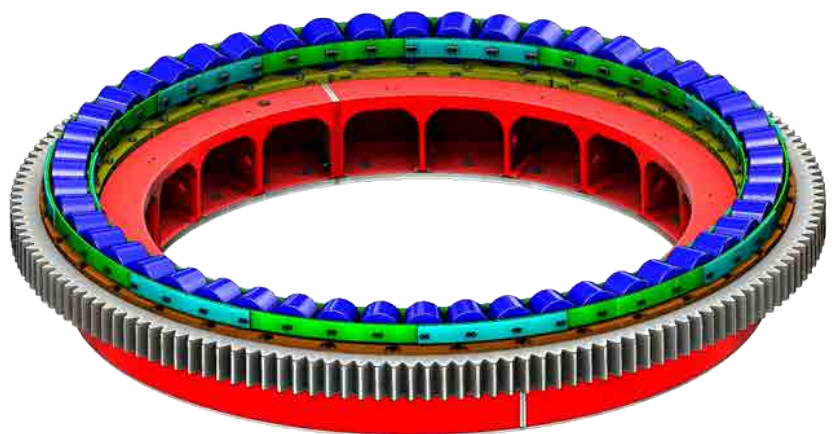
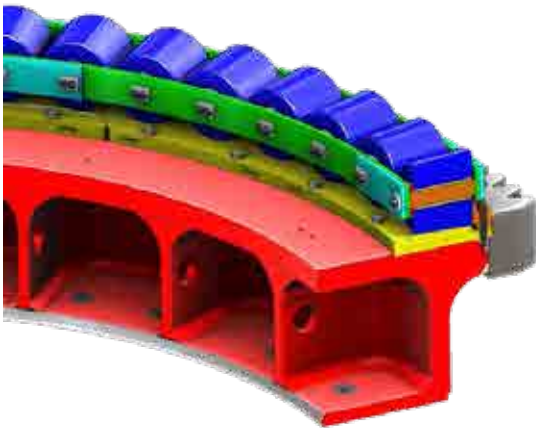

- AS1444 forged alloy steel ring rolled rack quench & tempered to 345-375 BHN.
- Ring rolled forging offers superior mechanical properties, more homogenous grain flow in the direction of the applied principal stresses, and increased forging reduction ratio.
- Vertical tool mark striations are removed by polishing the roots to improve the fatigue life of the gear.
- Shot-peened roots to -600Mpa residual compression to improve the fatigue life of the swing gear.
- Improved cast segmented high strength alloy hub welded to the rack. Optional improvement: mechanically attached rack.

ELECTRIC ROPE SHOVEL

PARTS & SERVICES

• SWING • PROPEL • HOIST & CROWD

SWING



- Hofmann swing shaft assemblies can be upgraded with HofCarb pinions.

PROPEL

- Hofmann improved propel shaft and assemblies.
- As an additional product improvement, splines can be induction hardened to increase the fatigue strength and wear resistance.

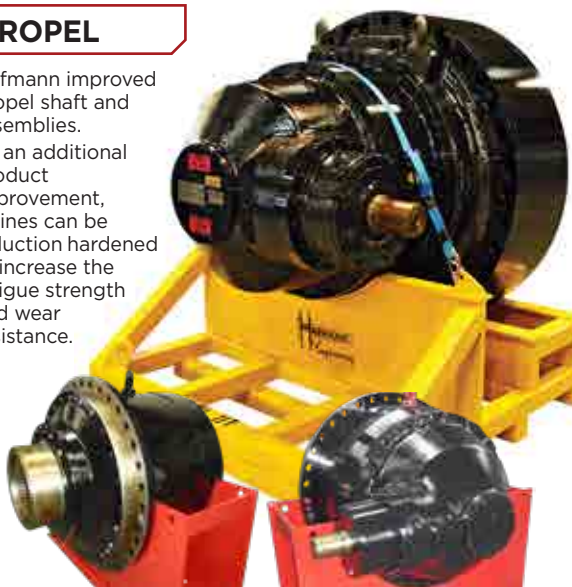

HOFMANN UPGRADED PLANETARY TRANSMISSIONS

New or service exchange.

- To suit Komatsu/P&H shovels 2800XPB, 2800XPC, 4100, 4100A, 4100C, 4100XPB & 4100 XPC.
- To suit Caterpillar/Bucyrus shovels 495, 495B, 495HR, 495HD, 495HF & 7495.
- Upgraded materials for improved service life.
- Upgraded HofCarb heat treatment for increased service life on case hardened components.
- Completely re-engineered.
- Fully interchangeable.
- To maximise service life, only high quality bearings are used.
- Precision form ground planet sets to AGMA 12 minimum quality.
- Accurately cut internal ring gears to AGMA 10 minimum quality.
- Fully tested prior to despatch.
- Fully supplied complete with transport frame and anti-brinelling devices fitted.

HOIST



- Improved hoist drums and drum gears available.
- Upgraded input coupling using cardan shaft arrangement available.

CROWD

- Hofmann improved crowd drums and drum gears available.
- Both drum designs: using bearings or Toughmet bushes, can be offered.

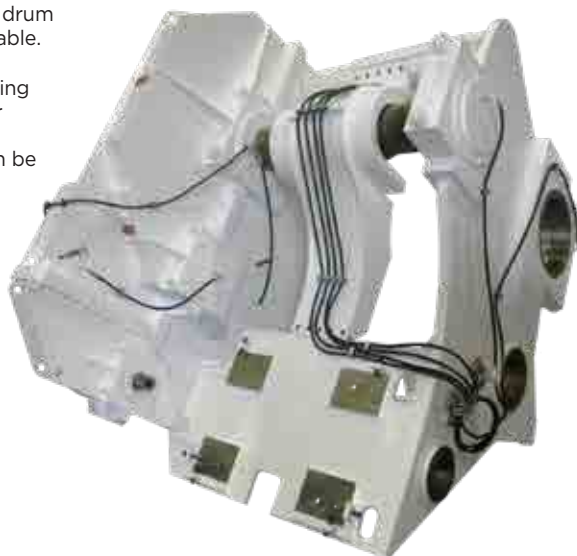



SWING PINIONS

Product improvement:

- Original pinion was induction hardened and failed due to excessive wear and case cracking.
- Upgraded 18CrNiMo7-6 pinion material, case hardened to 60 - 62 HRC and precision form ground to AGMA 12 minimum quality.



SWING GEAR & SHAFT ASSEMBLIES

- Swing gear assemblies in one or two piece designs for P&H, Bucyrus and Marion shovels.
- Replaceable thrust rails for increased life
- Improved swing shaft assemblies in induction hardened pinion or one piece carburised designs.



LOAD ROLLERS, REAR & FRONT IDLERS

- **Load rollers:** forged from high alloy steel with quench and tempered core and surface hardened to 52 HRC (min) providing up to 25-30% increase in life.
- **Rear idler rollers:** forged high alloy steel quench and tempered with increase of up to 20% life.
- **Front idler:** standard or upgraded with external gearing providing up to 30% life increase.



TRACK PADS

- Manganese steel up to 18% Mn.
- Alloy steel quench and tempered.
- Induction hardened alloy steel, quench and tempered, followed by deep case induction hardening in the pin bores. Optional induction hardening on the interfacing drive and running surfaces.



DRIVE TUMBLERS

- **New:** cast alloy steel quench and tempered'
- **Refurbished:** by weld repairing splines and drive lugs.
- Over pitched drive tumblers available to allow for stretching of the tracks.
- Optional induction hardening on the interfacing drive or running surfaces
- Thrust washers and seals.



CROWD PINIONS & RACKS

- Forged alloy steel dipper racks with finish machined tooth profile.
- Full range for all makes and models.
- Forged steel dipper racks alloy steel full finish machined tooth profile.
- Standard cast racks can also be supplied.



BOOMS, DIPPERS & DIPPER HANDLES

- Fabricated new to internationally recognised standards.
- Full or partial rebuilds.
- NDT inspection on repairs.
- On-site boring & welding repairs with Hofmann line boring machine.
- Pins, bushes & link replacements.
- Machined alloy racks can be offered as a product improvement.



ATTACHMENTS: ROPE SHEAVES & PADLOCKS

- New forged steel fabricated rope sheaves
- Full contour induction hardened rope grooves.
- Repaired and re-profiled.
- New or repaired padlock assemblies are available.
- All welding to internationally recognised standards followed by full thermal stress relieving.



UPGRADED SWING PINIONS

- Pinion shaft quenched and tempered.
- Induction hardened gear teeth and spline before finally shot peening the stressed shaft area. The F.E.A. performed on this re-design confirms a 50 x life improvement.
- Pinion can also be supplied fully assembled with bearing and cartridge ready to install.

HYDRAULIC EXCAVATOR PARTS & SERVICES

• CATERPILLAR/BUCYRUS/TEREX/O&K • HITACHI • KOMATSU • LIEBHERR

Hofmann Engineering offers a wide range of product improved replacement parts interchangeable with O&K, Terex, Bucyrus, Caterpillar, Liebherr, Hitachi & Komatsu Hydraulic Excavators. Major components include sticks, booms, side frames, all transmissions (swing & propel), complete undercarriages and slew bearings.



LIEBHERR

- Product improved propel and swing drives for R996B.
- New, overhauled or service exchange gearboxes.
- Like for like replacement internal gearing or upgraded internal gearing with the latest technology in case hardening by carburising or induction hardening and high precision grinding to DIN 5/AGMA 12 (min).
- Full gear quality inspection on all gearing using the latest gear inspection technology.
- Test run prior to despatch.

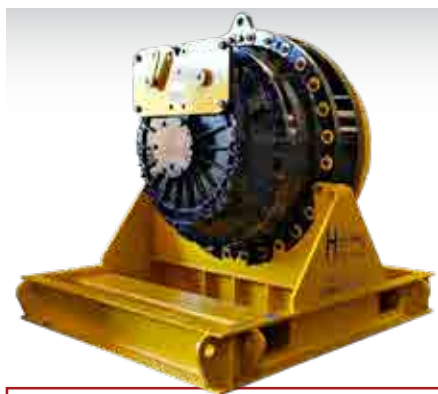

HITACHI

- Product improved propel and swing drives for EX3600/5500.
- New, overhauled or service exchange gearboxes.
- Like for like replacement internal gearing or upgraded internal gearing with the latest technology in case hardening by carburising or induction hardening and high precision grinding to DIN 5/AGMA 12 (min).
- Full gear quality inspection on all gearing using the latest gear inspection technology.
- Test run prior to despatch.



**CATERPILLAR/BUCYRUS
/TEREX/O&K**

- Product improved propel and swing drives for RH120 / RH170 / RH200 / RH340 / RH400.
- New, overhauled or service exchange gearboxes.
- Like for like replacement internal gearing or upgraded internal gearing with the latest technology in case hardening by carburising or induction hardening and high precision grinding to DIN 5/AGMA 12 (min).
- Full gear quality inspection on all gearing using the latest gear inspection technology.
- Test run prior to despatch.

HYDRAULIC EXCAVATOR PARTS & SERVICES

• CATERPILLAR/BUCYRUS/TEREX/O&K • HITACHI • KOMATSU • LIEBHERR

NEW IMPROVED SWING RACK

- AS1444 forged alloy steel ring rolled, quench & tempered to 345-375 BHN.
- Ring rolled forging offers superior mechanical properties, more homogenous grain flow in the direction of the applied principal stresses, and increased forging reduction ratio.
- Vertical tool mark striations are removed by polishing the roots to improve the fatigue life of the gear.
- Shot-peened roots to -600Mpa residual compression to improve the fatigue life of the swing gear.
- Improved cast segmented high strength alloy hub welded to the rack. Optional improvement: mechanically attached rack.

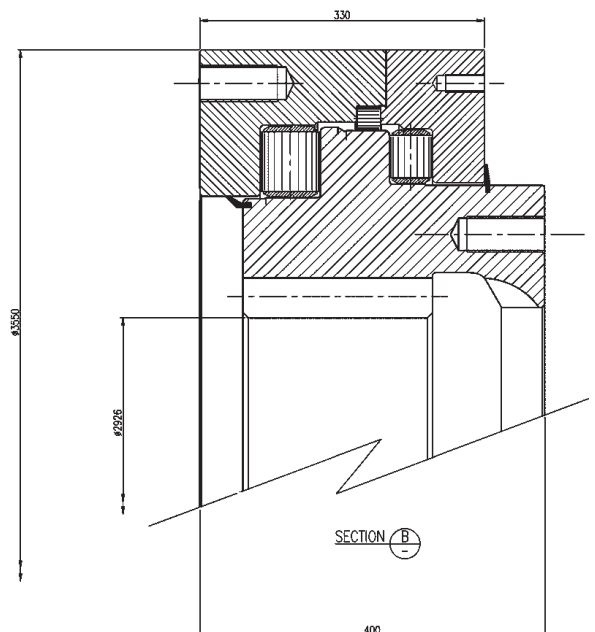
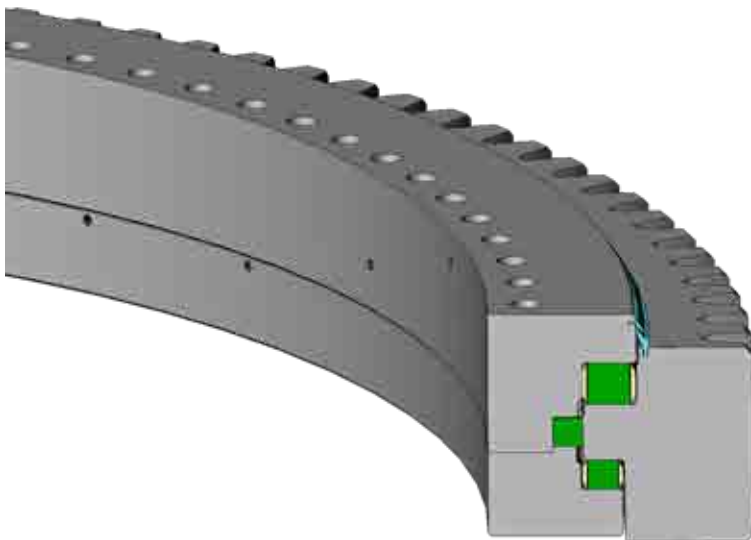
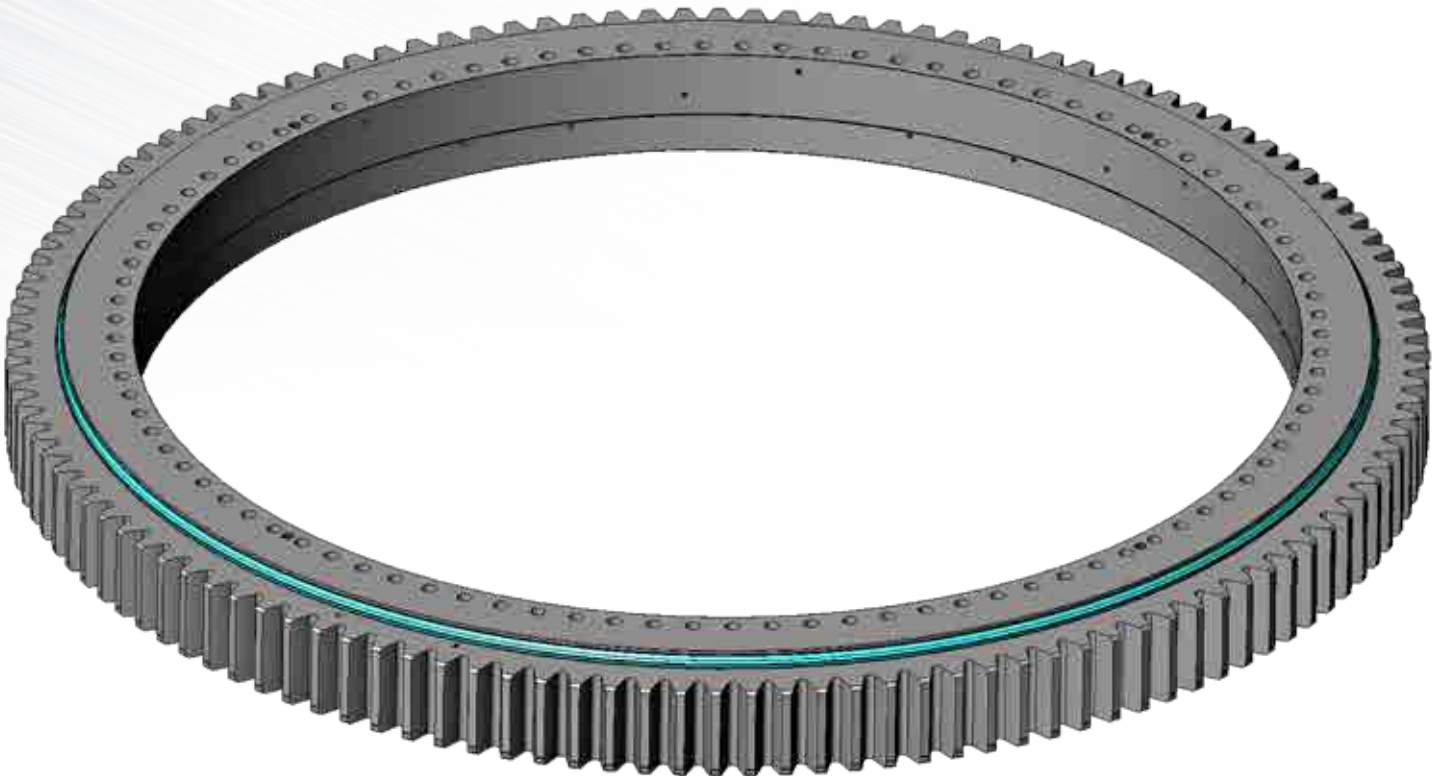

HYDRAULIC EXCAVATOR PARTS & SERVICES

• CATERPILLAR/BUCYRUS/TEREX/O&K • HITACHI • KOMATSU • LIEBHERR

SIDE FRAMES

- Overhauled or fabricated new.
- Full or partial rebuilds.
- NDT inspection on repairs.
- On-site boring & welding repairs with Hofmann line boring machine.
- Pins, bushes and link replacements.
- Complete fitouts and assembly of undercarriage components, which can include final drive load roller.

SIDE FRAME BEFORE REFURBISHMENT



CNC MACHINING OF CRITICAL AREAS



SIDE FRAME AFTER REFURBISHMENT





SWING TRANSMISSIONS

New or refurbished swing transmissions are available. Refurbished swing transmissions provide a cost-effective option and result in an "as new" product.



SLEW BEARINGS

- Designed and manufactured to suit your specific requirements, or re-engineered from sample.
- Induction hardening of the bearing surfaces is carried out using the latest technology.
- Each slew bearing is supplied with full certification covering material, heat treatment and dimensional checks.



LOAD ROLLERS, REAR & FRONT IDLERS

- **Load rollers:** forged from high alloy steel with quench and tempered core and surface hardened to 52 HRC (min) providing up to 25-30% increase in life.
- **Rear idler rollers:** forged high alloy steel quench and tempered with increase of up to 20% life.
- **Front idler:** standard or upgraded with external gearing providing up to 30% life increase.

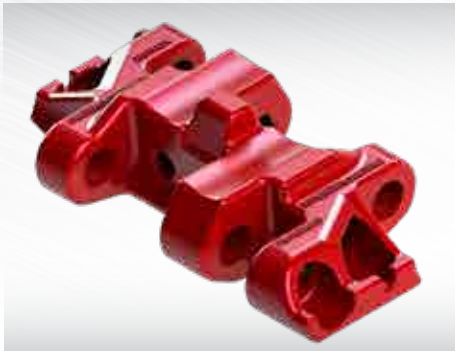

TRACK PADS

- Alloy steel quench and tempered.
- Induction hardened alloy steel, quench & tempered, followed by deep case induction hardening in the pin bores. Optional induction hardening on the interfacing drive and running surfaces.

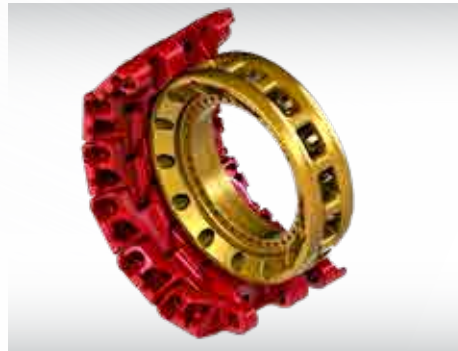

DRIVE TUMBLERS

- Highest quality castings both metallurgically, mechanically and dimensionally.
- Precision final machining.
- A comprehensive range to suit current models.
- Quench and tempered to 400 BHN for maximum wear resistance.



SPROCKETS

- Cast steel machined and heat treated.
- Precision final machining of sprocket teeth.
- Full range for all makes and models.



STICKS

- Fabricated new or rebuilt to internationally recognised standards.
- Full or partial rebuilds.
- NDT inspection on repairs.
- On-site boring and welding repairs with Hofmann line boring machine.
- Pins, bushes and link replacements.
- Machined alloy racks offered as a product improvement.



FINAL DRIVES

- Hofmann final drives are built to the highest standards using the latest material standards and heat treatment processes to achieve gear tooth hardness of 62 HRC.
- Gear geometry is optimised by the design engineers to provide maximum gear life.
- The gearing is manufactured to AGMA 12 (min). The gearing can be isotropic treated/ super finished to 0.40Ra where required. A higher surface finish reduces friction and vibration which extends the life of components.



REPLACEMENT GEARING & PARTS

- Replacement gears and components for all hydraulic excavator areas.
- Heat treatment options include through hardened, induction hardened and case carburised.
- Precision form ground or hard cut to AGMA 12 (min).

SLEW BEARINGS

• NEW • REPAIRED • ALL MODELS • TO 16M DIA

SLEW BEARINGS AND SLEW GEARS

Designed and manufactured to meet specific customer requirements. Fully interchangeable with the OEM equipment. Product improvement options are available which include induction hardened bearing surfaces and gear teeth.

Each slew bearing is supplied with full certification covering material, heat treatment and dimensional checks. Hofmann Engineering's experience in this field extends to over 100 complete slew bearings of various types.

On-site inspection, consulting, machining and installation is also available.



NEW OR REPLACEMENT TO SUIT THE FOLLOWING:



STACKER/RECLAIMER & CRANE SLEW BEARINGS

- THYSSENKRUPP
- VOEST ALPINE
- O&K
- MITSUBISHI
- FAVCO



HYDRAULIC EXCAVATOR SLEW BEARINGS

- CATERPILLAR
- KOMATSU
- LIEBHERR
- DEMAG



DRAGLINE/SHOVEL SLEW BEARINGS & GEARS

- CATERPILLAR/BUCYRUS /MARION
- KOMATSU/P&H/PAGE

FROM OLD....

Hofmann Engineering has extensive experience in the production of high quality slew bearings.

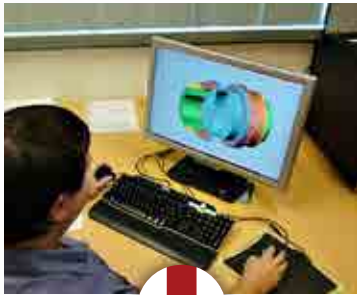

DESIGN & DRAWING

Our team of highly trained engineers will prepare plans from your existing slew bearings or new designs can be made to fit your requirements.



VERTICAL BORING

A range of vertical boring machines turn slew bearing rings up to 16 meters in diameter.



GEAR CUTTING

External and internal slew gears are cut on an extensive range of CNC and conventional gear cutting machines.



INDUCTION HARDENING

In addition to induction hardened bearing raceways, tooth by tooth full contour induction hardening of gear teeth can also be supplied. This process results in a hard, wear resistant case up to 10mm deep, supported by a tough impact resistant core.



INSPECTION LABORATORY

Coordinate Measuring Machine with lead involute and pitch software to enable the complete inspection of components in a climate controlled laboratory environment.



ASSEMBLY

All slew bearings are trial assembled prior to despatch.

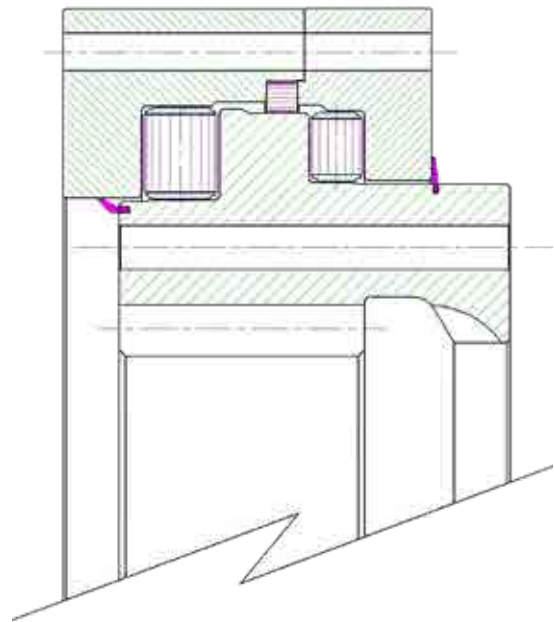

HARD WEAR RESISTANT CASE:
Max case hardness = 58HRC
Max case depth = 10mm
Max residual compressive stress depth = 10mm

TOUGH IMPACT RESISTANT CORE:
Core hardness = 300BHN



Section tested piece showing the induction hardened profile.



Computerised full contour induction hardening of large Slew gears and bearing race ways.



....TO NEW

HOFMANN TRACK PADS

• INDUCTION HARDENED ALLOY STEEL • ALLOY STEEL • MANGANESE

REPLACEMENT PARTS INTERCHANGEABLE WITH:

- Caterpillar/Bucyrus/Terex/O&K
- Hitachi • Komatsu/P&H
- Liebherr



INDUCTION HARDENED ALLOY STEEL

HIGHEST WEAR RESISTANCE & STRENGTH

Hofmann induction hardened alloy steel track pads are suitable for the toughest environments as they feature the highest wear resistance.



ALLOY STEEL

GOOD STRENGTH & STRETCH RESISTANCE

- Offers superior strength, greater resistance to plastic deformation and less maintenance over manganese steel track pads thus reducing operating costs and downtime.
- Do not require deformation ('work hardening') to increase hardness. The hardness is inherent in the 'through hardened', quench and tempered material.
- The alloy elements are selected to ensure minimal deformation in working areas of the track pad thus increasing life.
- PRODUCT IMPROVEMENT: manganese bushes can be removed and the bores can be induction hardened to increase strength, reduce elongation and minimise pitching errors with the tumbler.
- PRODUCT IMPROVEMENT: Alloy steel track pads can be upgraded to induction hardened alloy steel track pads.



MANGANESE

COST EFFECTIVE

Cost effective material that offers acceptable toughness and work hardening properties.

PRODUCT IMPROVEMENT:

- The sectional thickness of the load roller path area can be increased.
- The Mn & Mo chemical composition can be enhanced to increase work hardenability and reduce metal flow.
- Manganese track pads can be upgraded to induction hardened alloy steel track pads.

COMPLETE MANUFACTURING PROCESS CONTROL GUARANTEES QUALITY AND PERFORMANCE



1

DESIGN & DRAWING

The Hofmann team of highly trained engineers prepare plans from existing track pads or develop new designs to specific customer requirements. 3D modelling using Solidworks and Finite Element Analysis (FEA) are used to optimise design performance.



2

SPECIFICATION DEVELOPMENT

Detailed specifications are prepared to cover the complete manufacturing process from start to finish. A Portable Coordinate Measuring Arm is used to aid precise product development and inspection.



3

CASTING

Track pad castings are supplied to detailed specifications from approved and audited foundries worldwide.



4

QUENCH & TEMPERING

Alloy steel track pads are quench and tempered which results in an excellent combination of mechanical properties.



5

CASTING INSPECTION

Thorough inspections of the castings are undertaken to ensure the highest quality products.



6

CNC MACHINING

Track pad bores are precision finish machined on state of the art range of CNC machining centres.



7

INDUCTION HARDENING THE ROLLER PATH

An induction hardened roller path results in reduced wear leading to longer service life.



8

INDUCTION HARDENING THE DRIVE LUGS

Distortion due to wear is reduced, resulting in longer effective lifespan of the drive lugs and the drive tumbler, and therefore the entire undercarriage.



9

INDUCTION HARDENING THE BORES

Combined with hardened pins, wear resistance is greatly increased, resulting in an overall lower wear rate.



10

TEMPERING

Track pads are tempered after induction hardening to improve impact strength and durability in the induction hardened zone.



11

FINAL INSPECTION

Track pad castings are fully dimensionally inspected including UV crack detection and hardness testing to ensure the highest quality standards are met.



12

PACKAGING & DESPATCH

Track pads are painted, assembled and palletised for transport and despatched according to the customers order specifications and international shipping regulations.

INDUCTION HARDENING OF TRACK PADS

Induction hardened track pads, pins, rollers and drive tumblers have improved wear resistance and increased resistance to plastic deformation. During induction hardening, compressive stresses are generated in the surface of the part which increases fatigue resistance. By selecting the right material and hardness for individual components, wear can be controlled even further. Manganese track pads cannot be induction hardened due to their material properties.



Drive lugs, roller surfaces and pin bores can be induction hardened. Alternatively, bores can be fitted with case hardened bushes (carburised to 3mm). Pins are normally made of either 4140 or 4340 and are quenched, tempered and induction hardened to the required depth. Case carburised pins are available for extreme working conditions where the pins have proved to be wearing excessively.



ROLLER PATH

Hardened case depth = 17.5mm



DRIVE LUGS

Hardened case depth = 13mm



PIN BORES

Hardened case depth = 8.5mm

Track pads that are to be induction hardened are made from a high alloyed steel that is first normalised and tempered. The track pads are then quench and tempered which results in an excellent combination of mechanical properties.

HOFMANN TRACK PADS - INTERCHANGEABLE WITH OEM PRODUCTS

EXCAVATORS

KOMATSU

- PC3000
- PC5500
- PC8000



Induction hardened alloy steel.
Induction hardened bores,
roller path and drive lug.

HITACHI

- EX2500
- EX3600
- EX5500/EX5600
- EX8000



Induction hardened alloy steel.
Induction hardened bores,
roller path and drive lug.
Modified heavy pads can be
made for extreme working
conditions and applications.

CATERPILLAR

- 6030
- 6040
- 6050
- 6060
- 6090

O&K

- RH120C
- RH120E
- RH170B
- RH200
- RH340
- RH400



Induction hardened alloy steel.
Induction hardened bores,
roller path and drive lug.

Available in:

- OEM bushed design
- Hofmann improved bushless design
 - Less maintenance
 - Better performance
 - Competitive price

LIEBHERR

- 994
- 995
- R996 Single Pin
- R996 Twin Pin
- R9800



Induction hardened alloy steel.
Induction hardened bores,
roller path and drive lug.

Offset roller path for smooth operation

ROPE SHOVELS

P&H

- 2800 XPB/XPC
- 4100A
- 4100XPB
- 4100XPC
- 100XP



Cast manganese, work hardened for added service life. Also available in the Hofmann deep engaging style which are interchangeable with the P&H DELTA® pads.

For ultimate performance these can be supplied in induction hardened alloy steel.



Deep engagement style

CATERPILLAR

- 7495
- 7495HD
- Drills

BUCYRUS

- BE 495HR Shovel
- BE 495BI/BII/HD



Alloy steel quench and tempered with induction hardened bores, roller path and drive lug.

Proven Hofmann reinforced core and overall design for longer life and high performance.

HAUL TRUCK PARTS & SERVICES

- MECHANICAL & ELECTRICAL FINAL DRIVE TRANSMISSIONS

Technical innovation, brand reliability, and excellent sales and service ensures Hofmann Engineering Haul Truck parts and components are unrivalled. With high levels of performance and backed by the highly skilled in-house R & D team, Hofmann Engineering's product improved componentry are perfectly suited for the demands of the harshest mining environments.



PRODUCT RANGE



Hofmann Engineering's product range incorporates both mechanical and electrical final drive transmissions and associated components interchangeable with OEM products for the following mining trucks:

CATERPILLAR

797, 793, 789,
785 & 777

KOMATSU

930E, 830E

GE WHEEL MOTORS

772, 776, 787 & 788

HITACHI

EH4500-1
EH4500-2
& EH5000

LIEBHERR

T282B &
T282C



GE MOTORISED WHEEL KOMATSU TRUCK

- Manufacturing from new or rebuild final drives and gearboxes depending on the customers' requirements.
- Complete strip and assessment.
- Worn gearing can be reground on our precision gear grinders.
- Badly worn and pitted gears will be replaced with new improved high performance gears meeting DIN, AGMA, ISO or Australian Standards.
- Full assembly and test run.



793F FINAL DRIVE

- Rebuilt improved final drives to deliver lower cost per ton operations by achieving longer component life cycles.
- Manufacturing of new complete drives or supply fully compatible replacement parts.
- Inventory stocks available on certain replacement parts.



EH4500-2 REAR WHEEL DRIVE & FRONT AXLE ASSEMBLIES

- Complete front and rear axle assemblies for smoother faster planned maintenance.





793F REAR AXLE ASSEMBLY

- In-house engineering and product improvement towards greater quality and more efficient solutions.
- Greater life cycle capacities and lower cost per ton operations from product improved components.



EH4500-2 PLANETARY BUILD

- New or rebuilt sub-assemblies for more efficient on-site maintenance.
- Completely manufactured in-house with full MDR records.



EH4500-2 WHEEL MOTORS IN TRANSPORT FRAMES

- Customised anti vibration transport frames.
- Load rated and safe for mine site use.



PLANET GEARS & PINION SHAFTS

- Precision ground and timed gear set assemblies.
- Multiple assemblies matched for gearbox installation (Load Sharing).
- DIN or AGMA QA inspection.



FRAME COUPLINGS

- Precision manufactured components suitable to be interchanged with OEM.
- Components can be custom manufactured to suit the customers' requirements.



RING GEARS

- Full contour, tooth by tooth induction hardened to 52 - 56 HRC and precision ground to AGMA 12 minimum quality.
- New or weld repaired as per customer requirement.



CATERPILLAR PLANET GEARS

- **Product Improvement:** Caterpillar Planet Gears
- Case carburising improves the quality and life of gearing.
- Chromium carbide precipitation reduces the coefficient of friction between the working components, increases residual compression and wear resistance.
- Increase in fatigue resistance at the roots of gears.
- Shot-peened roots.



GEAR GRINDING

- Precision gear grinding facilities capable of achieving DIN 2 (AGMA 15).
- Completely climate controlled manufacturing area.
- Profile and lead modifications available.



GEAR INSPECTION

- State-of-the-art gear inspection facilities to ensure lead, involute and pitch quality is achieved.
- Gear inspection to international standards.
- Ultraviolet crack detection.



LOAD TESTBED

- 3 MW load testbed capable of testing 2 wheel motors in one test.
- Full vibration analysis, temperature and oil reports available as part of the commissioning process.
- Delivering confidence to customers around the world.



FINAL DESPATCH

- Finish gear coated with Molybdenum disulphide C220.
- Corrosion protected.
- Fully protected in fumigated timber crates for air or sea freight.

STACKERS & RECLAIMERS

PARTS & SERVICES

- THYSSENKRUPP
- O&K • VOEST ALPINE
- MITSUBISHI

New or reconditioned stacker reclaimer components interchangeable with the OEMs. Components include gearboxes, slew bearings and bogie wheels. The reconditioned service economically returns equipment to "as new" condition.

A design review can be conducted on underperforming gearboxes to identify design improvements that will reduce noise, increase performance, and extend service life. Bogie wheels can be spin induction hardened to reduce wheel and rail wear.



AN ALTERNATIVE TO NEW:

Old bucket wheel gearbox



Reconditioned bucket wheel gearbox

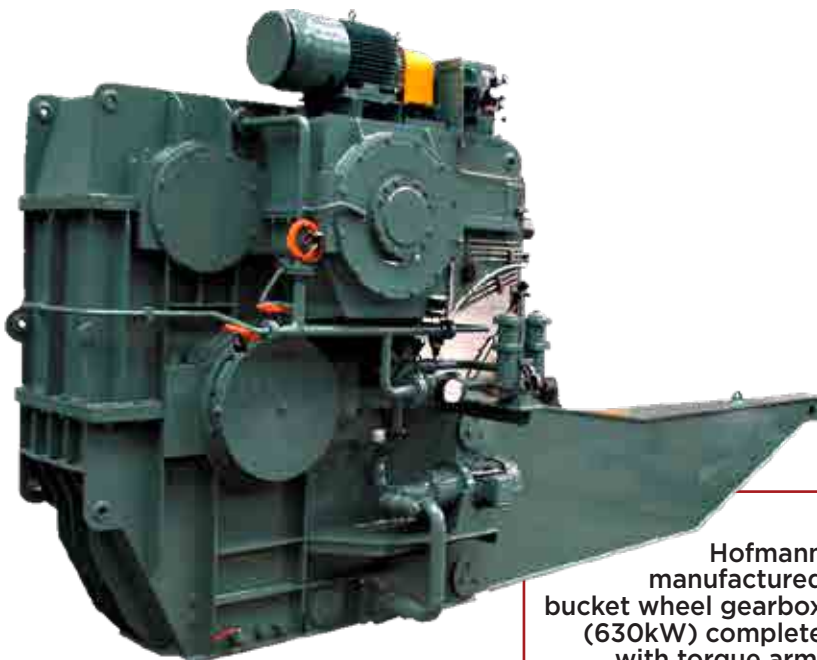

Hofmann
bucket wheel gearbox
(630kW) complete
with torque arm.
(see over for further details)



BOGIE ASSEMBLIES

Complete bogie assemblies including fabrication, machining and assembly of equalisers plus supply and assembly of gearbox/motor and wheels.



SLEW BEARING TO 15M

- Designed and manufactured to suit customers' requirements, or re-engineered from sample.
- Induction hardening of the bearing surfaces is carried out using the latest technology.
- Each slew bearing is supplied with full certification covering material, heat treatment and dimensional checks.



ON-SITE MACHINING OF SLEW BEARINGS

- Perform large site machining projects up to 14m dia.
- Slew bearing installation and alignment also performed by our skilled technicians.



TORQUE SPLITTING BUCKET WHEEL GEARBOX

One of the most complex gearboxes to be manufactured at Hofmann Engineering. The gearbox is fully fabricated in 3 sections from grade 350 plate and weighs 22 tonnes when complete with torque arm.



BUCKET WHEEL GEARBOX

The gearbox comprises all carburised and ground gearing from the spiral bevel input stage to the torque splitting arrangement achieved through the planetary stage. The circular casing on the outside of the gearbox encloses the planetary stage gearing.



SITE SERVICES

- Complete assembly of stackers and reclaimers.
- Site inspections including slew bearing and gear measurements, UT and MPI crack detections, and gearbox inspections.
- Site fitting includes gearbox, slew bearing and bucket wheel change outs.

SLEW GEAR MANUFACTURE



ROLLING SLEW GEAR RIM FORGED HOFALLOY PLATE

10.2 metre forge/fabricated slew gear manufactured from AGMA grade 2 plate during the initial rolling of the rim plate. The plate shown is 150mm thick, however plate is stocked up to 220mm thick.



GEAR CUTTING THE SLEW GEAR

- The 4 segment 10.2m dia slew gear is being cut as an assembled ring. This ensures accurate pitching over all the split lines.
- Individual segment lengths from 1m to 12m possible.



FINAL PREPARATION OF COMPLETED SLEW GEAR

- Final preparation for despatch including corrosion protection prior to securing in fully enclosed crates.
- Assembly simplified by having long segment lengths.

DEFENCE PARTS & SERVICES

• NAVY • ARMY • AIRFORCE

Hofmann Engineering's key capabilities are wide-ranging and include gear manufacture, precision and heavy machining, fabrication, design and site services to support Defence and Aerospace projects with complete end-to-end solutions.

Quality assurance certification by Lloyds to AS/NZ/ISO 9001 and AS 9100, complements Hofmann Engineering's Quality Management System.

A total quality culture and continuous quality improvement touch every aspect of all products, services and customer support.



DEFENCE PARTS & SERVICES

• NAVY • ARMY • AIRFORCE

Hofmann Engineering is a leading manufacturer and globally recognised engineering solutions provider to the defence industry. Supplies include a range of specialised components and sub-assemblies to the Australian Airforce, Navy and Army as well as major defence primes as part of their global supply chain. Hofmann Engineering are specialists in emergency breakdown situations and have supported the Australian defence force over many years by providing solutions needed to redeploy an asset within the shortest possible timeframe. Hofmann Engineering has one of the largest 3D, 5-axis machining capacities in Australia.



**FIN STABILISER MANUFACTURE
AND REFURBISHMENT**



MILITARY APC CHASSIS



**JOINT STRIKE FIGHTER
PRODUCTION TOOLING**

CAPABILITIES

Full turnkey tooling service incorporates:

- Engineering design
- Manufacture
- Fabrication
- Assembly
- Accredited testing and installation
- Electro/Mechanical site service

ACCREDITATION

- AS9100 Aerospace Standard - Hofmann Cheltenham, Melbourne (formerly Metaltec).
- ISO9001 accreditation for Perth and Bendigo Manufacturing sites.
- Hofmann Engineering is an approved supplier to:
 - BAE Systems-Australia
 - BAE Systems-UK
 - GE Rolls-Royce Fighter Engine Team
 - Australian Submarine Corp
 - Rolls Royce Australia Services Pty Ltd
 - Thales • Boeing • DMO
 - Raytheon
 - Naval Ship Management



WING FLAPERON TOOL

DEFENCE PARTS & SERVICES

• NAVY • ARMY • AIRFORCE

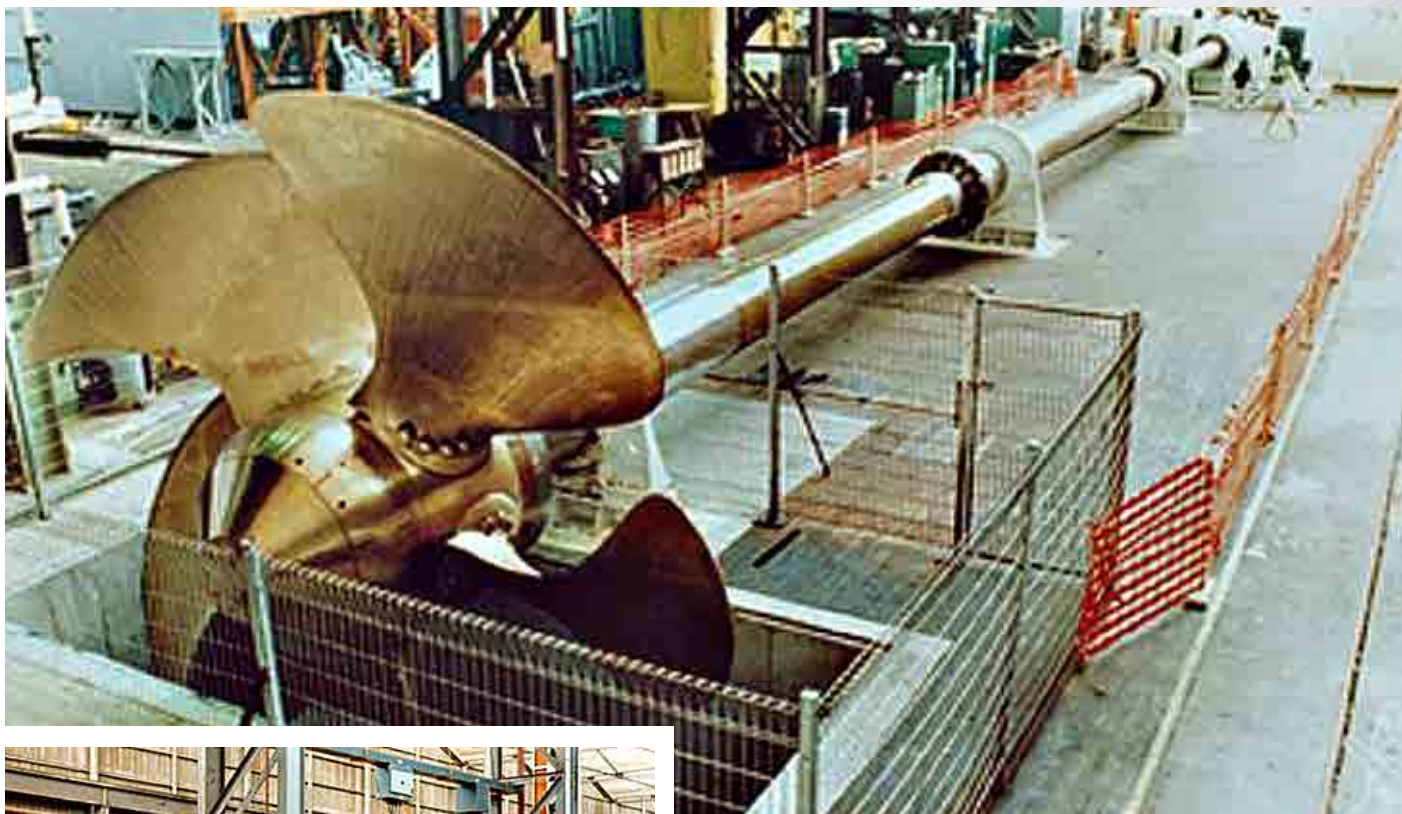

PROPULSION SHAFT MANUFACTURE AND REFURBISHMENT



PROJECT EXPERIENCE

AIR

- BAE Systems
 - Hawk horizontal stabiliser skins
 - Hawk weapons pylons
- C130H
 - Inboard flap assembly jigs
- DRCACS
 - R&D activity
- F/A - 18
 - Horizontal stabiliser tooling
- MRTT
 - Tooling validation
- Nimrod
 - Weapons pylon assembly jigs
- P3 Orion
 - Nacelles
 - Replacement floor panels
 - Tooling
- 737 Wedgetail
 - Wing tip radome tool

LAND

- BAE Systems
 - M113 APC and armoured hull upgrades
- Thales
 - Bushmaster

SEA

- ANZAC Frigates
 - Machined components
- Collins Class Submarine
 - Machined components/ Propeller shafts and generator rebuilds
- Jindivik
 - Jig refurbishments
- Mine Hunter Vessels
 - Machined components
- Nulka
 - Decoy system components
- Amphibious and afloat support
 - Gearbox repairs

HOFMANN NAVAL BOW THRUSTERS

• VARIABLE PITCH

BOW THRUSTER INCLUSIONS

- Coded fabricated housings
- Spiral bevel gears
- Nickel aluminium bronze castings
- Assembled and tested in-house
- 3rd party certified



Pictured above left to right: The Governor of Western Australia Kim Beazley, Rear Admiral Raydon Gates and Hofmann's Managing Director Erich J Hofmann inspecting the completed Bow Thrusters that were made for FINCANTIERI and have been exported to Italy.



HOFMANN NAVAL ANZAC CLASS FRIGATES

L-BAND RADAR INSTALLATION JIG

Hofmann Engineering specialises in customising engineering solutions for its customers. As part of the upgrade project for the ANZAC Class frigates, Hofmann Engineering collaborated with the Royal Australian Navy and BAE System Australia (BAE) on the design and manufacture of a custom L-Band Radar installation jig. The basic design work was executed by BAE with Hofmann Engineering being instrumental in improving the robustness of the unit. Many upgrades and modifications were incorporated to achieve safe and reliable remote operation, making allowance for the ship's movement.



FINAL ASSEMBLY AND TESTING IN THE FACTORY



**L-BAND JIG BEING REMOVED
FROM PACKING CRATE**



PREPARING FOR THE LIFT



**TESTING THE JIG ON THE
"DUMMY" MASK HEAD
DURING DEVELOPMENT
AND TESTING**

HOFMANN NAVAL SUBMARINES

COLLINS CLASS SUBMARINES

- Specialist maintenance works
- In situ machining
- Project management
- OEM Componentry
- Periscope repair & maintenance
- 24/7 Service

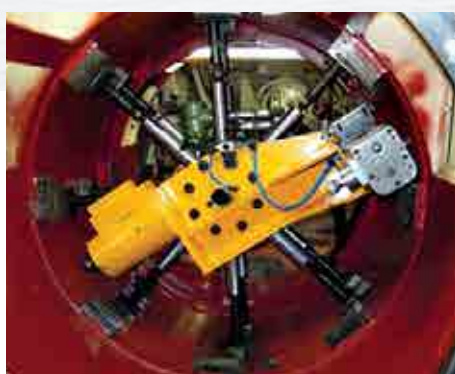

IN SITU MACHINING

- Qualified team of in situ machinists.
- Development of specialised equipment to tackle even the most difficult of tasks.
- Machines are developed to fit through the hatches.
- Efficient set ups reduce down time.
- Ability to machine to accurate tolerances even with the vessel being in the water.



COMPONENT MANUFACTURE

- Capstans.
- Propellers & shafts.
- Windlass.



TIMING GEARS

- Timing gears before packaging and despatch to our customer.
- Gear undergoing CMM (Co-ordinate Measuring Machine) inspection. A report will be supplied to the customer as part of the OQE requirements.

SPACE SURVEILLANCE TELESCOPE

22m diameter slew Bearing incorporating a world's first self-aligning roller technology.

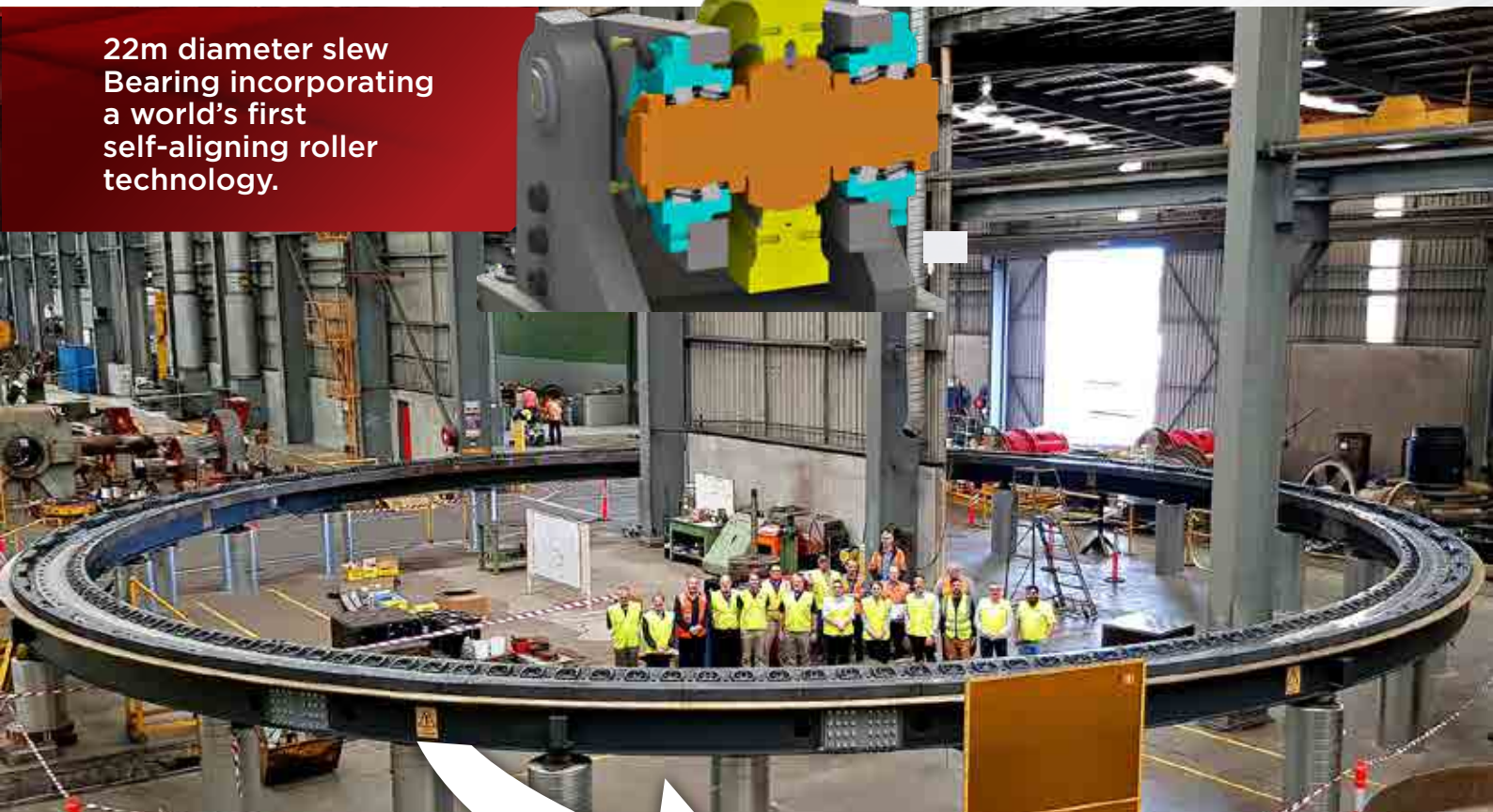

Hofmann Engineering were contracted by managing contractor, Sitzler Pty Ltd to manufacture, supply and install the Azimuth gantry ring, bogie drive assemblies and door mechanisms which are considered critical for rotating the dome enclosure of the large space surveillance telescope (SST) facility. The telescope facility, located on the North West Cape of Western Australia, is a joint project between the Commonwealth of Australia Department of Defence and the United States of America Air Force.

In the initial stage, Hofmann Engineering worked very closely with Sitzler and US based M3, the original design engineers of the SST facility, to produce detailed manufacturing drawings from their original design. At the request of the Department of Defence, Hofmann Engineering became heavily involved in the redesign and improvement of these critical components of the rotating dome enclosure.

Hofmann Engineering recommended and implemented the inclusion of a self-aligning roller with a tapered track and tapered roller arrangement which exceeded tight vibration and noise specifications. This design solution is providing an improved level of operational and 'whole of life' enhancement to the original design, delivering a high performance mechanism for the operation of the telescope.

The design of the self-aligning roller technology was commissioned by the Integrated Managing Contractor (Sitzler) on behalf of the the Commonwealth of Australia.

Hofmann Engineering's Site Services team carried out the installation of the gantry ring, bogie and drive assembly components of the rotating dome enclosure. Representatives from the highly regarded Massachusetts Institute of Technology (MIT) Lincoln laboratory were present at the first rotation of the 275 tonne dome enclosure in March 2019 and they were very impressed with its smooth and almost inaudible rotation.

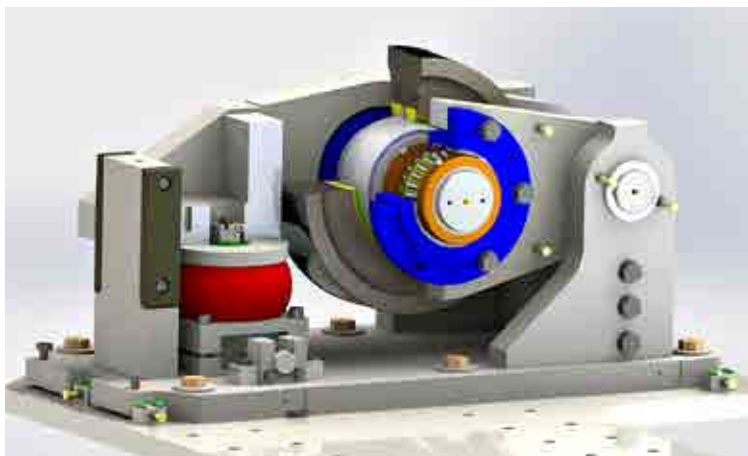



**GANTRY RING
INSTALLATION**



**GANTRY RING AND BOGIE
ASSEMBLIES INSTALLED**



**DOME UNDER
CONSTRUCTION**

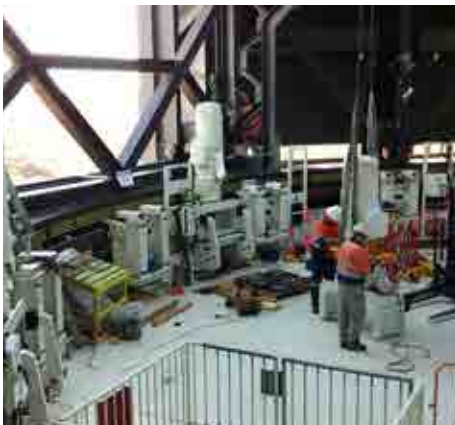

**DRIVE MECHANISMS
INSTALLATION**



**SHUTTER DOOR
INSTALLATION**



**SHUTTER DOORS
INSTALLED & OPERATIONAL**

AEROSPACE TOOLING & EQUIPMENT



More than 40 years' experience in the aerospace industry coupled with the acquisition of Metaltec in 2009 have firmly established Hofmann Engineering as a globally recognised provider of engineering solutions in tooling to the aerospace industry.

Fully certified and accredited to AS9100, people, systems, and processes are finely attuned to the stringent requirements of the aerospace industry. Complete capability for model based manufacturing, 5-axis machining, 100% inspection processes, laser tracking, FOD procedures, all within in a globally competitive cost structure make Hofmann Engineering a world class aerospace tooling and equipment supplier.



CAPABILITIES

Full turnkey tooling service incorporate:

- Engineering design
- Manufacture
- Fabrication
- Assembly
- Accredited testing and installation

DEMONSTRATED SUCCESS

Solutions for major commercial and military aircraft programs include:

- Project management
- Lay-up mandrels
- Bonding fixtures
- Assembly jigs and fixtures
- Mould tools for composite manufacture
- Parts manufacture and assembly
- Cutting tools for alloys and composites
- Machining of exotic materials including Titanium, Inconel, Invar 36 and Aluminium, Nickel alloys
- Inspection and metrology



ACCREDITATION

Hofmann Engineering's aerospace centre of excellence in Melbourne is an approved supplier to:

- Airbus
- BAE systems
- Boeing
- GE Rolls-Royce Fighter Engine Team

PROJECT EXPERIENCE

Commercial Aircraft:

- B787 - Outboard flap
- B777 - Rudder (National Award Winner)
- B777 - Elevator (National Award Winner)
- B777 - Trim tab (National Award Winner)
- B767 - Slats
- B757 - Rudder hinges
- B747-8 - Krueger panel holding fixtures
- B737 - Krueger flaps
- B737 - Max Winglets
- A380 - Winglets
- A340 - Winglets
- A330/340 - Floor beams
- A330/340 - Landing gear doors

Military Aircraft:

- BAE Hawk - Tailplane skins
- BAE Hawk - Weapons pylons
- C130J - Inboard flaps
- F/A - 18 - Wing skins
- F35 - Wing skins
- P3 Orion Nacelles and centre fuselage floor beams Nimrod Wedgetail winglet

RAIL - PARTS & SERVICES

- TRACTION GEARING • BOGIE MANUFACTURE & UPGRADE
- WHEEL & AXLE COMPONENTS • INSPECTION & FAILURE ANALYSIS
- COMPONENT REFURBISHMENT



Australian made by the experts achieving the highest axle loads in the world.

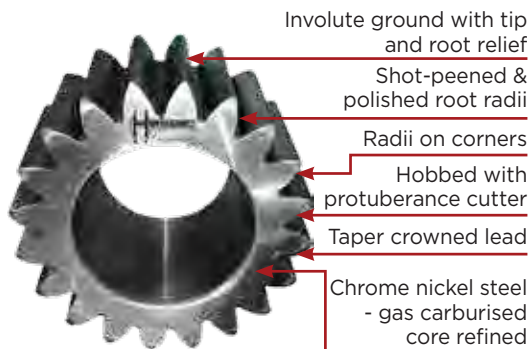

SPIRAL BEVEL GEARS

- Case carburised to 60 ± 2 HRC and precision cut to DIN 3 (AGMA 14).
- Capacity to manufacture spiral bevel gearing up to $\varnothing 2m$.

BULL GEARS

- Case carburised, shot-peened, ground and/or skived
- Tooth by tooth full contour induction hardened and ground
- Profile regrinding of old worn bull gears to better than DIN 5 (AGMA 12) accuracy (gears can remain on axle).



PINIONS

Case carburised and accurately ground including taper crowning. A shot-peened full root radius on pinions provides a substantial increase in strength.

STATE OF THE ART ROBOTIC BOGIE PRODUCTION

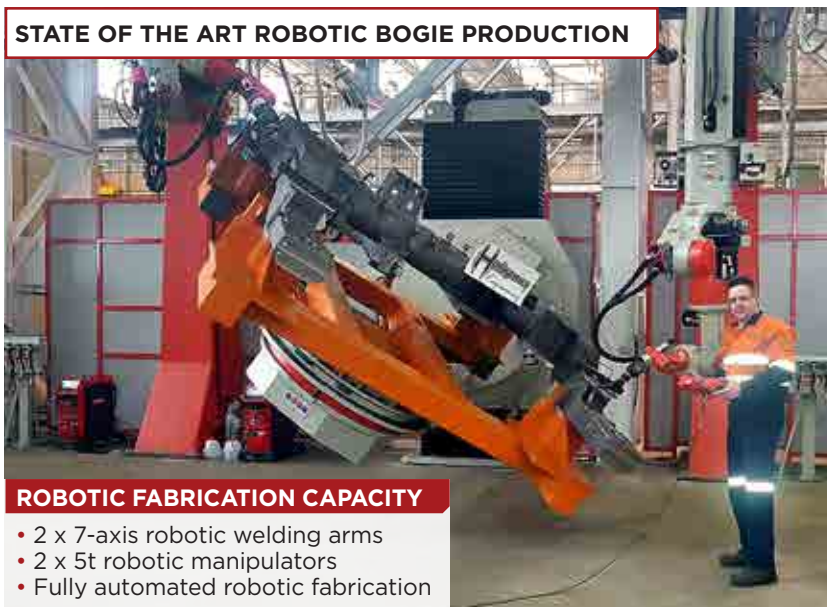

ROBOTIC FABRICATION CAPACITY

- 2 x 7-axis robotic welding arms
- 2 x 5t robotic manipulators
- Fully automated robotic fabrication



BOGIE MACHINING

Bogie frames are precision machined on CNC heavy machining centres.

BOGIE FABRICATION

CERTIFIED TO ISO3834 & EN15085

Bogie frames can be completely fabricated using both certified welders and robotic welding. Full stress relieving is also available.



MANUFACTURE & ASSEMBLY OF WHEELS & AXLES



MACHINING WHEELS

Forged wheels are finish machined on 5-axis CNC machining centres.

MACHINING AXLES

Axles are manufactured to AAR Standards or higher. Sourcing of forged material, NDT testing and finish machining are tightly monitored.

PRODUCT IMPROVED FORGED COMPONENTS

Hofmann forged rail componentry is product improved to permit higher axle loads and extend operational life.



COMENG POWERHEAD OVERHAUL

Hofmann Engineering have developed an overhaul process for the Comeng Powerhead that provides superior performance than the OEM product.

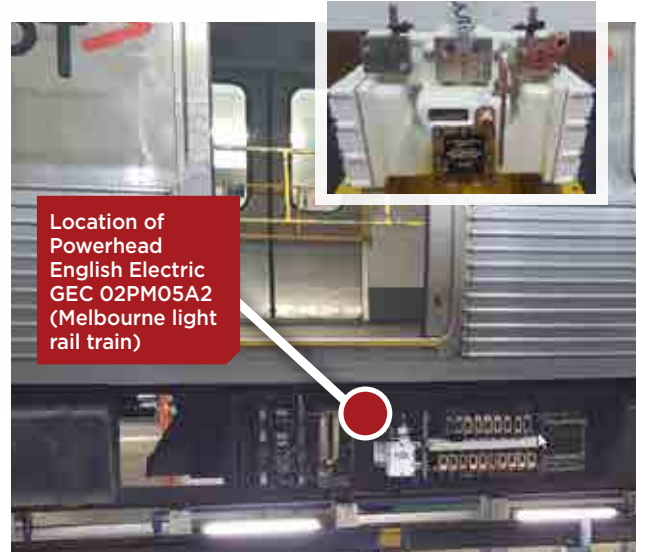

MACHINING LOCOMOTIVE ENGINE BLOCKS

Engine blocks are completely precision machined on floor borers. In situ line boring service with portable line boring machine is also available.



PORTABLE COORDINATE MEASUREMENT

Portable Coordinate Measuring Machines (PCMM) & laser trackers are used to measure manufactured components both in the workshop and on-site.



BOGIE UPGRADES

Examples: K Class bogie upgrade to suit Short G Class bearings. G Class bogie upgrade to suit heavy haulage bearings. Benefits: increased bearing life; increased axle load capacity.



METALLURGY

Complete metallurgical lab for:

- Quality control of heat treatment processes
- Metallurgical failure analysis
- Our specialty is failure analysis of gearing to AGMA and DIN standards.

HOFMANN'S RAIL TRACK RECORD:

BOGIE MANUFACTURE

- 882 off Melbourne High Capacity Metropolitan Train (HCMT) bogies are built in Bendigo.
- 330 off B Class Yarra Tram Bogies are built in Bendigo (165 Motor Bogies, 165 Trailer Bogies).

AXLE & WHEEL MANUFACTURE

- 1,764 off HCMT axles and 3,528 off HCMT wheels are manufactured in Cheltenham.
- Bochumer Verein Verkehrstechnik (BVV Germany) provides the design and the forgings.
- Hofmann Cheltenham has been audited and approved by BVV.

- Precision machining within 10 micrometers accuracy required for the wheels.

CAST PARTS

- Hofmann are manufacturing 18,000 cast parts for the HCMT.
- The castings are sourced by Hofmann directly from CRRC approved vendors.

FORGED HEAVY HAULAGE DRAW GEAR

- Hundreds of Hofmann Engineering's product improved forged F-type knuckles have

successfully been manufactured and put into service.

- Other forged draw gear is in development and testing.

HOFMANN RAIL KEY FEATURES

- One stop shop for rail manufacturing.
- Hofmann Bendigo currently has the most advanced bogie production line in Australia.
- Hofmann can assure sustainability of investments through the variety of its product range and the strong position in the defence sector.

OIL & GAS PARTS & SERVICES

As one of Australia's largest heavy engineering companies, Hofmann Engineering operates 24 hours a day, 7 days a week to offer exceptional service to customers in demanding industries. Emergency repairs and rapid rebuilds are a forte. A wide range of machines, components and special tools are available to successfully complete difficult assignments in compliance with international standards.



SUB-SEA BALL CHECK VALVES

Large 1500mm dia. Borsig subsea ball check valve completely overhauled and tested.



GAS LIQUEFYING PUMP MANUFACTURED AND TESTED UNDER LICENCE TO STORK

Hofmann Engineering continues to have licensing agreements with recognised OEMs for the manufacturing, assembly, and shop testing of precision valves and pumps.





1

SUBMERGED ARC WELDING OF SUB-SEA BALL VALVE

The ball valve is submerge arc welded and heat treated in an electric furnace (stress relieved).

- Welding performed, including Inconel overlay to 4130 and F22.



2

BALL VALVE FULLY MACHINED

Ball precision machined to give 100% clean up. Full magnetic particle and ultrasonic crack detection.



3

BALL VALVE FINISH GROUND

The ball is hard chrome plated, finish ground to a 0.02mm roundness tolerance, and polished to a 0.4 micron surface finish.



4

BALL VALVE ASSEMBLY

Assembly is handled by specialist valve technicians. Where required the assembly is carried out in a purpose built clean room.



5

BALL VALVE PRESSURE TESTING

Due to safety requirements, many high pressure valves are pressure tested in a below ground concrete walled pit. Certification for the testing is provided.



SWAGING TOOL REBUILT AND MODIFIED

Pile reforming tool for Goodwyn A Platform for straightening bent pylons. This tool was re-engineered, part manufactured and then tested.



TOP DRIVE DRILLING SYSTEMS

- Complete top drive drilling system rebuild service.
- Replacement parts include all gearing.
- The gearing is case hardened and ground to DIN 5 quality.



WINDLASS

- Complete windlass rebuild service.
- Replacement parts include all gearing, capstan, brakes and gearbox drive system.



TRIPLEX SLUSH PUMPS

- Complete triplex slush pump rebuild service.
- Replacement parts include all gearing and crankshafts.

WIND TURBINE GEARBOXES

Since 2008 Hofmann Engineering has been extensively involved in repairing and improving the life expectancy of various wind turbine gearbox models for local and overseas markets. Each repair and modification of wind turbine gearboxes is a complex project due to the required precision machining. As an independent service company, customers can have confidence in Hofmann Engineering's expert gearing knowledge, detailed analysis and technical reporting. Hofmann Engineering has carried out repair and modification projects on numerous models ranging from 500kW to 3MW all of which are tested in-house to full load capacity prior to installation.



WIND TURBINE GEARBOXES NEW & REBUILT

- STANDARD HELICAL
- PLANETARY

OEM models can be overhauled and rebuilt with improved high performance case hardened precision ground gearing. This ensures smooth, quiet, reliable operation.

- Flender
- Renk
- Valmet
- Hansen
- L&S
- Metso
- Clipper
- Gamesa
- Eickhoff
- Zollern



SLEW BEARINGS - Induction hardened and precision ground

AUDITING YOUR WIND TURBINE GEARBOX REPAIR SHOP

Do they have the equipment and know-how to rebuild your gearboxes?

COMPARE

OTHERS



	<p>GEAR DESIGN</p> <ul style="list-style-type: none"> • Do they have gear design and consulting services? • Do they have a full metallurgical laboratory for carrying out failure analysis? • Are they members of any gear standard associations? (AGMA, DIN, ISO) 	<p>?</p>	<p>✓</p>
	<p>GEAR INSPECTION</p> <ul style="list-style-type: none"> • Do they have a certified gear inspection laboratory to inspect gear accuracy? • Wind turbine gearing requires very high gear accuracy of DIN 3 or better. • Can they provide computerised printouts of lead, involute and pitch? 	<p>?</p>	<p>✓</p>
	<p>COORDINATE MEASURING MACHINE</p> <ul style="list-style-type: none"> • Do they have a Coordinate Measuring Machine for checking bore alignment and size of gearbox housings? • This is required for the planet carrier of the planetary stage on wind turbine gearboxes and components. 	<p>?</p>	<p>✓</p>
	<p>MACHINING/FABRICATION</p> <ul style="list-style-type: none"> • Do they have gear manufacturing facilities for producing improved replacement gearing? • Hofmann Engineering also fabricates and machines many of the wind turbine components. 	<p>?</p>	<p>✓</p>
	<p>HEAT TREATMENT</p> <ul style="list-style-type: none"> • Do they have heat treatment facilities for replacement gearing, including qualified metallurgists? • Carburising, induction hardening, nitriding, quench & tempering & stress relieving facilities? • Gas carburising to 1,800mm dia for the output stage gearing for wind turbines. 	<p>?</p>	<p>✓</p>
	<p>PRECISION GEAR GRINDING - EXTERNAL & INTERNAL</p> <ul style="list-style-type: none"> • Do they have modern, climate controlled gear grinding facilities, capable of producing accurate gearing to DIN 2 (AGMA 15) required to produce quiet running wind turbine gearing? 	<p>?</p>	<p>✓</p>
	<p>GEARBOX BACK TO BACK LOAD TESTING</p> <ul style="list-style-type: none"> • Do they have a gearbox testbed facility for load test running gearboxes? • Hofmann Engineering has full gearbox load test facilities to 3,000kW. 	<p>?</p>	<p>✓</p>
	<p>ON-SITE MACHINING & INSPECTION</p> <ul style="list-style-type: none"> • Precision Portable Coordinate Measuring Machine for checking bore alignment and accuracy in situ. • Portable line boring machine for re-machining worn gearbox housings in situ. 	<p>?</p>	<p>✓</p>
	<p>SITE INSTALLATION & SERVICE</p> <ul style="list-style-type: none"> • Do they have site crews trained in gearing to install and laser align gearboxes? • Are they able to provide on-site machining services? 	<p>?</p>	<p>✓</p>

POWER STATIONS PARTS & SERVICES

• STEAM TURBINES • COAL PULVERISING • GAS TURBINE GEARBOXES

Hofmann Engineering provides parts and on-site and workshop services for hydroelectric, steam and gas turbines, new pumps and valves, rotor refurbishments, casings and gearboxes.

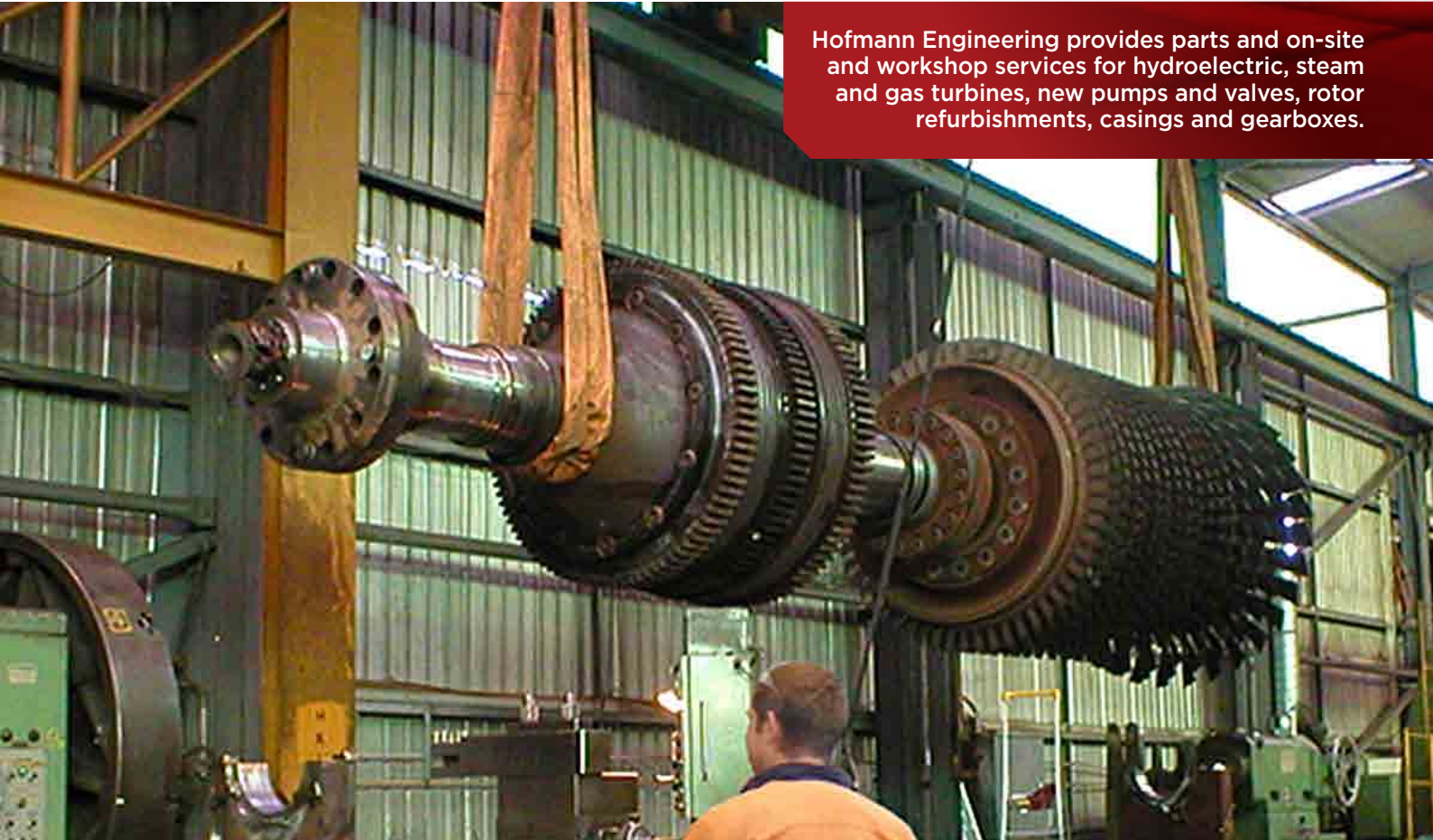

COMPLETE TURBINE OVERHAUL WORKSHOP

- 200 tonne crane facilities
- Bead blasting facilities
- Metrology laboratories including Coordinate Measuring Machines
- Portable Coordinate Measuring Machines
- Laser trackers
- Turning to 4.1m dia x 10m long and 1.87m dia x 35m long
- Floor borers up to 22m travel
- Vertical borers up to 15m dia
- 5-axis CNC machining centres up to 22m
- Machining of titanium
- Largest heat treatment facility in Australia
- Metallurgical laboratory





MANUFACTURE & REFURBISHMENT

- New seals from castings. (including S/S) or forgings.
- Re-engineering from samples.
- Re-caulking of seal strips to refurbish diaphragm seals.



MACHINING CASINGS

Casings are assessed for signs of distortion and re-machined if required.



MACHINING ROTORS

Removal of worn blades, replaced with new finish-machined blades.



GAS TURBINE GEARBOX INTERNALS

All components can be fully inspected, manufactured or refurbished. Gearing is precision ground to DIN 3 quality.



GAS TURBINE GEARBOX REFURBISHMENTS

Refurbishment service comprises of strip & assess, re-machine and/or replacement of parts and load testing.



COAL MILL GEARBOX REFURBISHMENTS

- On-site removal.
- Manufacture of components.
- Worm & wheel manufacture.
- Total refurbishment.
- On-site installation.



SITE SERVICES

On-site inspection with Portable Coordinate Measuring Machines (PCMMs) which can measure $\varnothing 2.4\text{m}$ to an accuracy of 0.025mm ($0.001''$) in one set up. The photo shows an operator performing a flatness check on a lower casing with a PCMM. Other portable measuring equipment includes laser trackers which can span 25m in one setup.



SPARE PARTS

- Studs from high temp steel.
- Stainless steel springs.
- Governor valves, rollers, positioners etc.
- Cylinder locking strips.
- Control shafts.



OVERHAULING A COMPLETE TURBINE ARRANGEMENT

- Offering complete turbine overhauls.
- An on-site customer office is available on request.

HYDRO POWER PARTS & SERVICES

As a globally recognised engineering solutions provider to the Hydro industry, Hofmann Engineering offers a range of specialized services to support the manufacture, refurbishment and reverse engineering of a wide range of hydroelectric turbine components.

REFURBISHMENT CAPABILITY FOR ALL MAJOR WORKS PACKAGES:

- Runner and shaft overhaul
- Top and bottom cover overhaul
- Guide vane overhaul
- Main inlet valve overhaul
- MIV Servomotor overhaul
- Refurbishment of all bearings (thrust runner, guide bearings etc.)
- Superfinishing thrust block using Supafina
- Small valves overhaul



LARGE VERTICAL BORER CAPACITY

- Top and bottom covers can be line bored on a vertical borer with a jig.
- Vertical borer capacity up to 15m diameter.

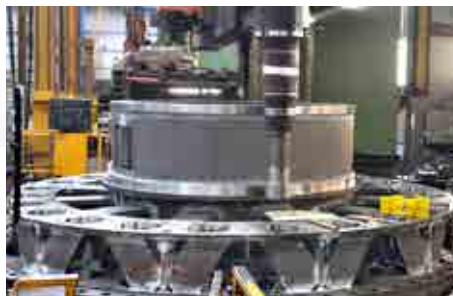

LINE BORING TOP & BOTTOM COVERS

- A purpose built line boring tool has been developed to machine the top and bottom covers.



TURBINE RUNNERS & SHAFTS

- Turbine Runner and shaft assembly is strip and assessed.
- NDT is conducted if required.
- Parts are manufactured new or refurbished, precision machined and assembled to customer specification.



MAIN INLET VALVE (MIV)

- MIV refurbishment includes strip and assess, machine, rebuild and pressure test in-house at Hofmann Engineering's Bendigo workshop.
- Photo of Snowy Hydro Tumut 1 Valve. Spherical door type. 75 tonne gross weight.



MIV SERVO VALVE & PISTON REFRUBISHMENT

- MIV Servo strip and assess .
- Replace piston .
- Full CMM inspection at Hofmann Bendigo and Perth workshops.
- Photo of Snowy Hydro Tumut 1 MIV Servo valve.



MIV SEALS - REPLACEMENT/SERVICING

- Supply of all wearable items including:
- MIV service, maintenance and emergency seals.
 - MIV Thrust washers and thrust bearings.



MIV SERVOMOTOR REFRUBISHMENT

- Refurbished MIV Servomotor for Snowy Hydro Tumut 1 leaving Hofmann Bendigo workshop.



TURBINE BEARING MACHINING

- Strip and assess turbine bearing housing, including NDT of bearing pads.
- Cast iron carrier with 6 white metal bearing pads.
- Precision machined to final dimensions.



SUPERFINISHING OF THRUST BLOCK

- High precision grinding/ 'SupFina' of the thrust runner face to correct flatness, perpendicularity to the bore and parallelism to the ring key mating surface.

GEAR MANUFACTURE

Hofmann Engineering is a name synonymous with, and world-renowned for high quality gearing. Specialising in the design and manufacture of all styles of industrial gears and gearboxes to suit specific customer requirements. These include helical, bevel, double helical, planetary, self-aligning and custom gears and gearboxes. A range of heat treatment options are also available including case carburising, quench and tempering, and induction hardening. Finish machining options include finish grinding and hard cutting.



68,000 KG DREDGE BUCKET WHEEL DRIVE GEARBOX

This gearbox operates 20m underwater for dredging mineral sands. The technical advancement of incorporating case hardened gearing throughout helped us win the order against some of the world's leading gearbox manufacturers.

1. DESIGN & CONSULTING

Analyse and solve your particular gear or gearbox problem using the latest gear design software to either D.I.N., A.G.M.A., B.S. or Australian Gear Standards.

- Industrial gearbox and gear design.
- On-site gear inspection and consultancy service.
- Computer-aided drafting (CAD).



2. TURNING

A range of lathes, both conventional and computer (CNC) controlled, for turning of gear blanks and shafts to 35,000mm long.

- Final grinding of shafts to 8,000mm long.



3. FABRICATION

Complete welding and fabrication facilities to 200 tonnes.

- Fabricated gearbox casings and gears.
- Rebanding worn gears via welding ring forging to original hub.
- Qualified welders with accredited welding procedures.



4. HORIZONTAL BORING

A range of both conventional and computer controlled (CNC) borers are available to 22,000mm x 5,000mm.

- Machining of large gearbox housings



5. GEAR HOBGING

Manufacture of high accuracy gears and worm wheels.

- Carbide skiving of case hardened gears.
- Computer (CNC) controlled accuracy (15,000mm dia).



6. LARGE GEAR CUTTING

Internal and external gearing to 15,000mm dia. x 2,500mm face width.

- Worn girth gears and slew rings can be recut.
- Full involute form carbide finish cutting of gears.



7. HEAT TREATMENT

One of Australia's largest specialised heat treatment facilities, encompassing:

- Oil quench & tempering, stress relieving.
- Gas carburising via pit furnace or fluid bed 1,800mm dia. x 5,000mm.
- Tool steel heat treatment.



8. INDUCTION HARDENING

Tooth-by-tooth full contour induction hardening to produce a hard wear-resistant case up to 20mm deep, supported by a tough impact-resistant core.

- Mill pinions, slew bearing races.
- Traction gears.
- Spin hardening of pins and splines.
- 15,000mm dia. x 2,500mm face width.



9. METALLURGICAL LABORATORY

An extensively equipped laboratory to facilitate both failure analysis and the inspection of control test pieces which are heat treated with every furnace charge.



10. GEAR GRINDING

Australia's most comprehensively equipped gear grinding facilities with a number of form grinders.

- 2,500mm dia. x 1,600mm face width x 40Mn.
- Completely climate controlled area.
- Profile and lead modification facilities (tip/root relief and crowning).
- CNC form grinding of both internal and external gearing to 2,500mm dia.



11. GEAR INSPECTION LABORATORY

A climate controlled inspection area for the verification of all gear geometry parameters.

- Lead involute and pitch inspection.
- Calibrated inspection machines.
- Crack detection.



12. GEAR BOX TESTBED FACILITY 3MW FULL LOAD

Every gearbox manufactured or overhauled is test run with a detailed test run report compiled.

- Partial load testing.
- Back to back full load gearbox test capability.
- DC stepless drive system.



13. COORDINATE MEASURING MACHINE

3D machine with lead, involute and pitch software to enable the complete inspection of small and large gearing.

- Climate controlled laboratory environment.
- Gears to 15,000mm dia. x 2,500mm face width.
- Gearbox housings and complex shapes.

PORTABLE MACHINE TOOLS

- LINE BORING • FACING • DRILLING • ID WELDING
- TURNING • KEYWAY CUTTING

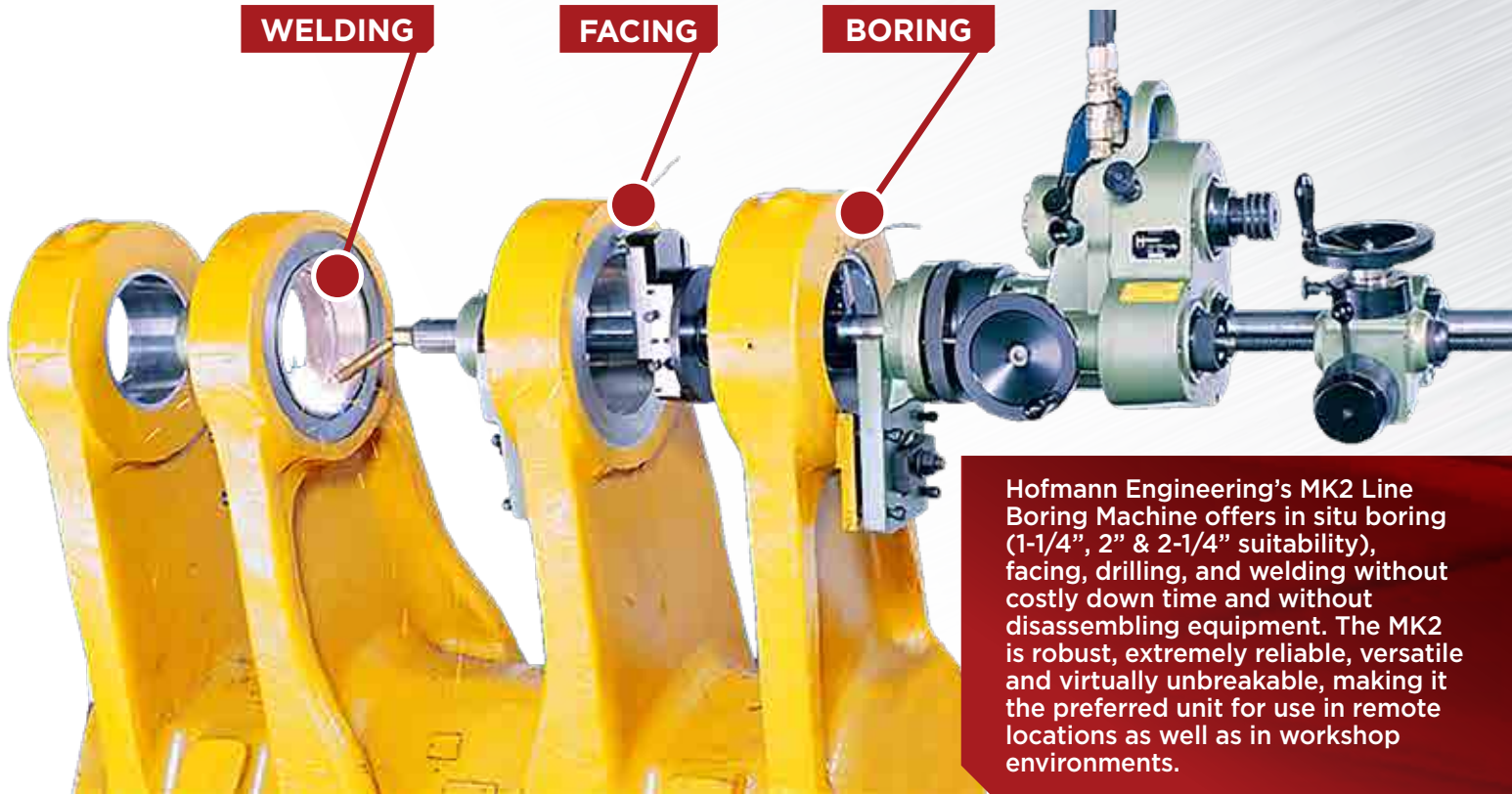

Hofmann Engineering's MK2 Line Boring Machine offers in situ boring (1-1/4", 2" & 2-1/4" suitability), facing, drilling, and welding without costly down time and without disassembling equipment. The MK2 is robust, extremely reliable, versatile and virtually unbreakable, making it the preferred unit for use in remote locations as well as in workshop environments.

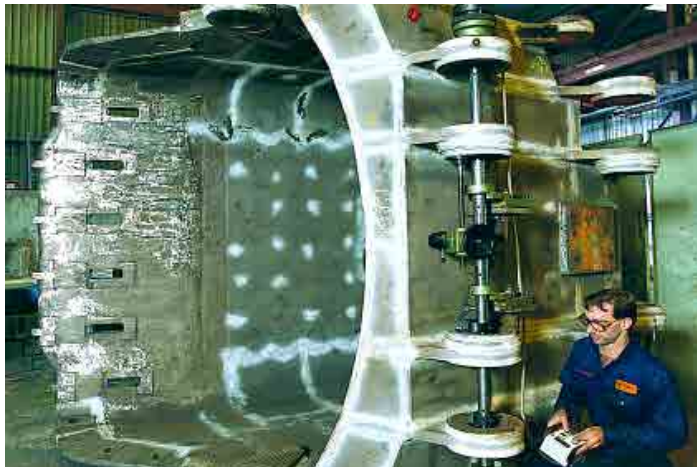

PORTABLE LINE BORING MACHINE KIT

- Line bore up to 1,000mm dia x 6,000mm in length @ up to 240rpm.
- Suitable for boring, facing, drilling.

WELDING ATTACHMENT

- Comes with 350 AMP MIG, STICK Welder.
- Weld bores from 25mm to 1,000mm.
- Storage box contains extension nozzles and special welding bars.

MACHINING CENTRE

- Table area of 1,500mm x 1,200mm
- Converts the line boring machine into a horizontal borer.
- Ideal for repetitive work.



FLANGE FACER

- Adjustable feed rate from 0.1mm/rev up to 0.7mm/rev (Gramophone finish).
- Faces from 160mm dia to 500mm dia.



FACING HEADS

- 180mm or 230mm dia facing head with variable feed.
- 600mm maximum facing dia 1,000mm with optional tool holder.



TAPER BORING HEAD

- Suitable for boring and facing.
- Universal tool for difficult work.
- Ideal for larger diameters.



KEY WAY MILLING MACHINE

- A valuable tool for both manufacturing and maintenance operations.
- Can cut new keyways without the need to disassemble gearboxes, drive shafts, etc.



ORBITAL LATHE

- Complete kit to turn up to 1,000mm dia x 3,000m long.
- Operate at speeds up to 40rpm.



MICRO BORE TOOL HOLDERS

- Complements the Hofmann Portable Line Boring Machine.



LARGE BORE KIT

- Enable boring up to 1,000mm dia.



ALIGNMENT GAUGE

- Essential for accurate support bearing alignment when machining multiple bores.



ON-SITE WORK

- Portable Line Boring Machine is in use on-site.
- Workshop quality repairs in the field.

CUTTING TOOLS

CUTTING TOOL SERVICE

SPECIAL PURPOSE TOOLING DESIGN AND MANUFACTURE

Special purpose cutting tools and holders are designed and manufactured to the highest level of precision to meet customer needs including reduced cycle time, reduced cost and improved quality.



HOFMANN PROVIDES:

Design and manufacture of special purpose tooling:

- Solid carbide and high speed steel form tools.
- Special pocketed cutting tool holders suitable for indexable carbide inserts.
- Brazed carbide form cutting tools.
- Special tool holders including arbours and mandrels.
- Special form insert manufacture and service.
- Form roller and sintered component finishing.
- Tooling and cycle optimisation to maximise production efficiency.
- Fast and efficient service utilising our multiple machining capacity.

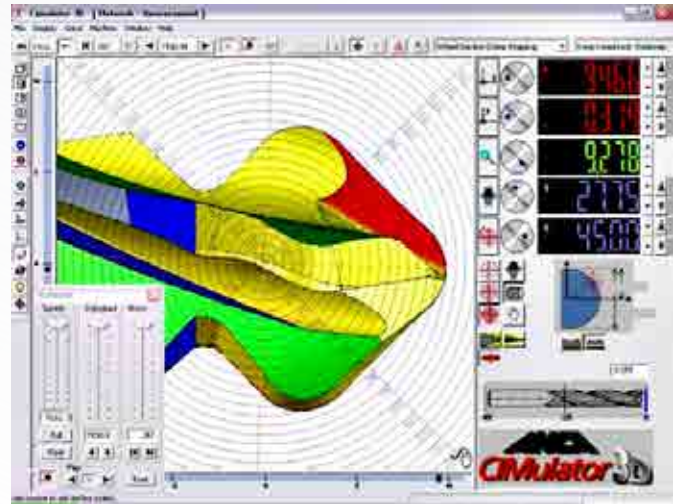

SPECIALISED CUTTING TOOLS

Hofmann's ANCA 5 axis CNC cutting tool grinding machines are equipped with ANCA's iView camera system. ANCA iView allows components to be measured while they are still in the machine to ensure perfect accuracy, whether it is a complex form tool, accurate ball nose cutter or profiled roller.

STATE OF THE ART TECHNOLOGY

All machines are networked to allow tools to be programmed and tested on ANCA's state of the art tool grinding simulation software, prior to being loaded onto any of the machines, allowing more efficient and accurate tool grinding.



DESIGN AND MANUFACTURE

Complex form tools with high accuracy are produced with Hofmann Engineering's grinding technology and techniques. Cutters can be PVD coated to suit application needs. Tooling can also be reconditioned to the original manufacturer's specifications to achieve required tool life and cost.

EXPERIENCED PROFESSIONAL SERVICE

Hofmann Engineering's 5-axis machining capability covers the manufacture of complex components, tool holders, pocketed tooling and arbours from almost any desired material with high accuracy. CNC cylindrical, jig and optical profile grinding facilitates the manufacture of form inserts, rollers and other components as required.



AEROSPACE ACCREDITED

Hofmann Engineering is one of the only cutting tool service companies in Australia with a quality system that is Aerospace industry accredited to AS9100.

FOOD PACKAGING TOOLING & SERVICE

- FOOD & BEVERAGE CANNING & PACKAGING TOOLING SPECIALISTS
- CUTTING TOOLS SUPPORT CENTRE FOR HASSIA/ERCA • YOGHURT CUTTING TOOLS



The food pack and canmaking tooling support centre at Hofmann Engineering provides world class manufacturing capability for specific customer requirements. A single source, fully managed service for the manufacture of precision canmaking and food packaging tooling, including die refurbishment and maintenance is provided. Re-engineering services are also available. A purpose built, climate-controlled manufacturing facility, and a specialist team of highly skilled tradespeople, ensure that the precision and high standards demanded of this industry are achieved. A dedicated section ensures shorted lead times, fast delivery and rapid response times to all breakdown and maintenance work.



CAPABILITIES

MANUFACTURE:

- All canmaker's tooling requirements
- New end making double dies
- Canning and end making tooling
- Seamer tooling - seaming chucks and seaming rollers

REFURBISHMENT:

- Hassia and Erca tooling/form fill and seal
- Canmakers' die sets

RE-ENGINEERING SERVICES | EMERGENCY BREAKDOWNS



YOGHURT CUTTING TOOLS



THERMO FORM TOOLING



CANMAKING TOOLING



FOOD & BEVERAGE CAN TOOLING



Z BARS



RE-ENGINEERING SERVICES



HIGH PRECISION TAB DIE TOOL

Enhanced life using high performance coatings.

EQUIPMENT RANGE

CAD/CAM DESIGN SOFTWARE INCLUDING

- Catia v5
- Unigraphics NX4-6
- ProE

A RANGE OF PRECISION 2-, 3- & 5-AXIS NC MACHINES

INSPECTION & METROLOGY LABORATORY INCLUDING:

- Coordinate measuring machines.
- Laser trackers.
- Climate-controlled environment.

CUTTING TOOLS SUPPORT CENTRE

Hofmann engineering offers world class toolmaking capabilities and provides a single source, fully managed service to customers.

- Expertise in precision toolmaking.
- Excellent technical knowledge of yoghurt cutting tools.
- World class quality and workmanship.
- 2.5 times more price competitive than OEM.
- 10 to 12 week lead time on refurbishments.
- Fast quotation process.
- Technical support.



PRODUCT IMPROVED TAB DIES

Titanium coated for longer service life.



CERAMIC DOMER PRESSURE RING DIE

For forming bottom end of can.

DEMONSTRATED SUCCESS

Hofmann Engineering has a vast experience in providing engineered solutions to various food packaging companies.

PRESS SHOP

A well-equipped and fully independent production pressing facility with the capability for both short run batches and high volume production.

The facility specialises in:

- Automotive component pressing
- Supplying whitegoods and general manufacturing sectors
- Deep drawing of steel, stainless steel, aluminium and copper
- Post press operations such as spot and projection welding, machining and assembly.

Pressing capabilities include single and double acting presses ranging from 60-700 tonnes, catering for dies up to 10 tonnes, with off-coil capability. Hofmann Engineering's broad range of presses allow production flexibility and responsiveness for urgent production requirements.



A RANGE OF PRESSED COMPONENTS



SOLAR PANEL FRAMES



AUTOMOTIVE COMPONENTS INCLUDING 4WD BULL BARS

CAPABILITIES

DESIGN:

- Progressive and deep drawing press metal tooling.
- Jigs and fixtures.
- Turnkey projects.

MANUFACTURING:

- Press metal stamping.
- Duplex or triplex dies for small batch runs.
- Off coil stamping for large production runs.
- Deep drawing expertise in steel, stainless steel, aluminium and copper.
- Coil handling capacity up to 3 tonnes with feeders to 1m in width.

QUALITY:

- CMM Reporting
- PPAP Submissions (Pre Production Approval Process)
- ISO Accredited AS9100 and ISO9001

PRESS SPECIFICATIONS

VERSON - 700 TONNE

- Size of bed: 2,740mm x 1,370mm
- Shut height: 2,100mm single action

BRITISH CLEARING - 500 TONNE

- Size of bed: 2,400mm x 1,524mm
- Shut height: 1,016mm single action

DANLY - 500 TONNE

- Size of bed: 2,100mm x 1,524mm
- Shut height: 914mm single action

JIANGSU YANGLI - 500 TONNE

- Size of bed: 1,500mm x 1,000mm
- Shut height: 650mm single action



ABOVE: A range of materials: copper, aluminium and steel pressings.
LEFT: Smelter pot door covers with hinges & latches welded on.



SUGAR MILLS

PARTS & SERVICES

Hofmann Engineering has the experience and technology to supply all sugar mill drive train needs. Supplies and services include high and low speed gearing, shafts, lubrication and sealing solutions, crush roll pinions, planetary drives, consulting and site services.

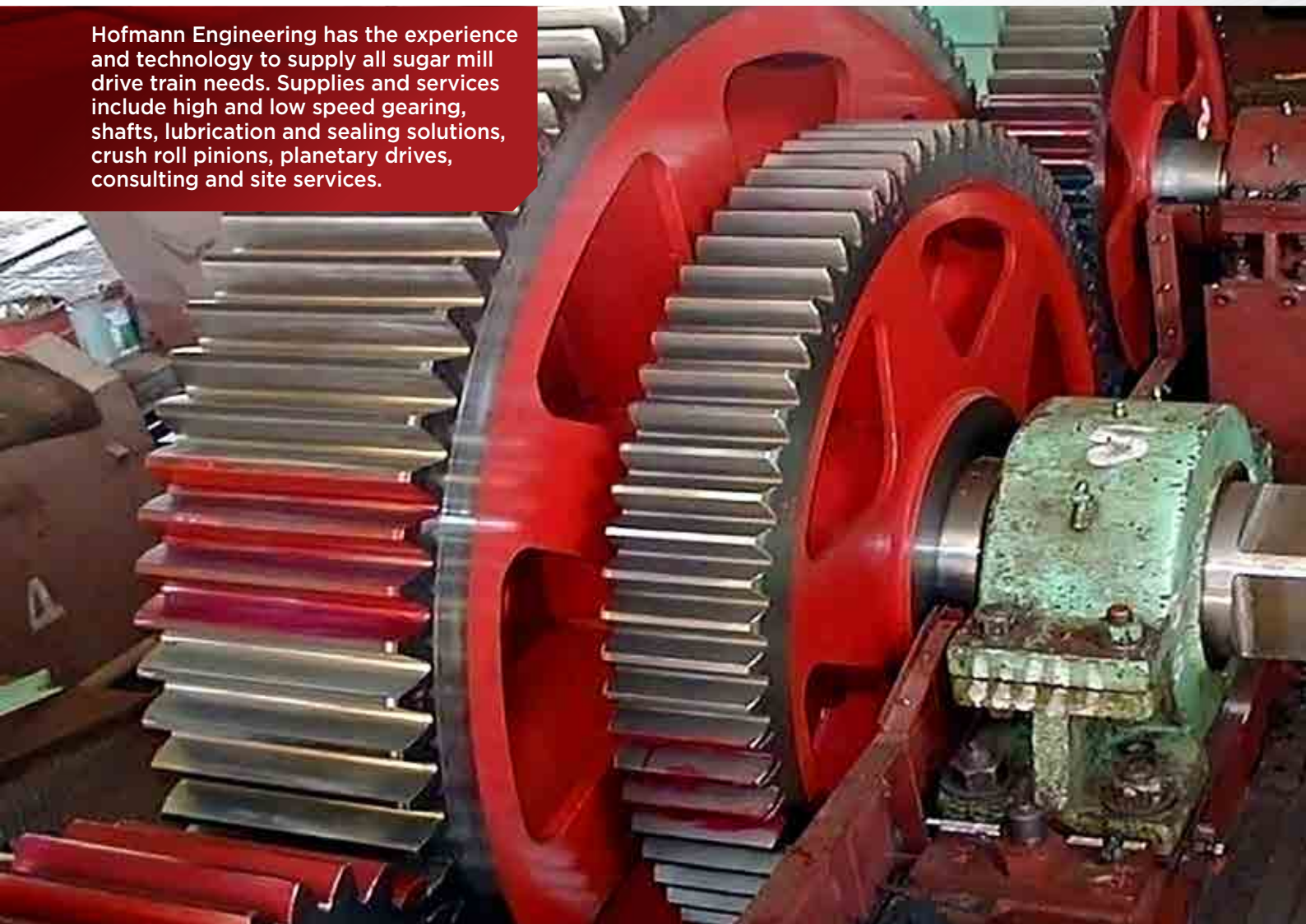

LOW SPEED PINIONS

- Through hardened (to 360 BHN).
- Induction hardened (to 55 HRC).
- Case carburised (to 62 HRC).

CAPACITY

Size: 2,500mm dia. x
1,600mm face width.
Quality: AGMA 15 (DIN 2).

LOW SPEED GEARING

- SG iron.
- Cast steel (to 320 BHN).
- Austempered SG iron (to 450 BHN).
- Forged fabricated (to 360 BHN).
- Forged fabricated induction hardened (to 55 HRC).

CAPACITY

Size: 15,000mm dia. x
2,500mm face width.
Quality: AGMA 10 (DIN 7).

RE-RIMMED GEARS

- Remove old rim and weld new rim to hub with full penetration welding.



HIGH SPEED GEARBOXES

- Replacement gearing and new gearboxes.
- Ratio changes and power upgrades.
- Case-carburised to 62 HRC and precision ground to AGMA 12 (DIN 5).
- White metal bearing manufacturing and reconditioning.



CRUSH ROLL PINIONS

- Cast to 300 BHN.
- Forged to 300 BHN and CNC cut to AGMA 6 quality. Eliminates casting inclusions that can cause fatigue fracture.
- Induction hardened to 55 HRC and CNC hard cut to AGMA 6 gives 200% improvement in pitting and 70% improvement in bending strength.

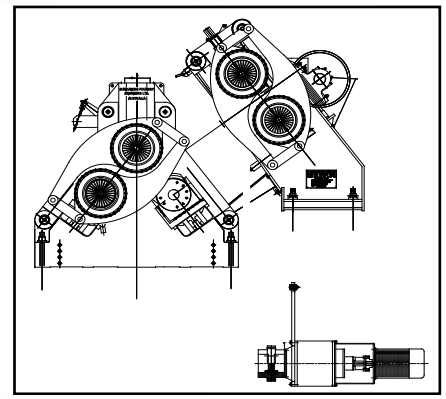

CRUSH ROLL PLANETARY

- Planetary drives use electric motors and eliminate crush roll pinions while still allowing centre distance adjustment.
- Precision gears, case hardened and ground to AGMA 12 quality.
- Standard modular design minimises spare parts capital and can be changed out in less than one shift.



SPECIAL GEARBOXES

Special gearboxes can be designed to fit existing foundations as a direct replacement of OEM drives. (Flender, Falk, Valmet, David Brown etc.).

- Power upgrades, ratio changes and replacement parts available.
- Torque-splitting gear drives.



LUBRICANT SUPPLY

In alliance with Klüber Lubrication of Germany, Hofmann Engineering offers a range of products, directly formulated to protect in-house designed and manufactured gearing as an integral part of a complete gear protection package.

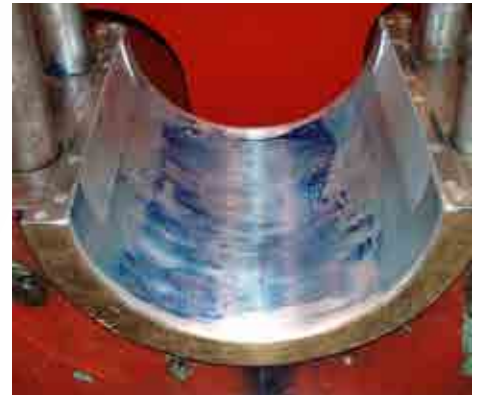

LOW SPEED JOURNAL BEARINGS

- White metal
- Bronze
- Pedestals and caps
- High tensile studs and nuts
- Full reconditioning and installation available



GEAR RE-RIMMING

The process of gear re-rimming:

1. Existing gear material is tested to ensure compatibility with the new rim material.
2. Rim is machined off leaving the bare diaphragm.
3. New forged rim is welded to diaphragm by submerged arc full penetration welding.
4. Full contour induction hardened to 55 HRC and hard cut to AGMA 10.
5. Full NDT to ensure structural integrity.



ON-SITE INSPECTION & CONSULTING SERVICE

- Inspection and assessment of mill and drive train.
- Failure analysis including engineering and gearing design review, Finite Element Analysis and metallurgical analysis.



SITE SERVICES

- Laser alignment of gear trains.
- Gear and pinion installation.
- Reconditioning of worn gearing using Hofmann Engineering's reconditioning procedure.
- White metal and bronze bearing installation including scraping.

SITE SERVICES

• CONSULTATION • INSPECTION • MACHINING • FITTING

Hofmann Engineering is renowned for solving site problems where others fail. Specialised site service teams are deployed globally for installation and general servicing of gearing and other manufactured products.



SPECIALISED MACHINING AND FITTING ACROSS THE GLOBE



ON-SITE MACHINING OF MILL SHELLS

- Special trunnion journal alignment tooling to insure that both trunnion journals are inline.
- Mill refurbishment.
- Shell crack inspection and weld repairs including stress relieving.



HOFMANN ON-SITE GEAR REPAIR & RECONDITIONING PROCEDURE

Using the Hofmann Engineering case hardened pinion as the accurate master reference, the worn mating gear is precision ground in situ to match. A special chemical etchant is applied to recondition the worn mating gear.



WORLDWIDE MILL INSTALLATION & SERVICE

- Experienced team available to plan, manage and install: girth gears, pinion assemblies, gearboxes and inching drives.
- Fully equipped with all tooling, for laser aligning, machining, fabrication and mill drive adjustments.



TRUNNION JOURNAL MACHINING & REPAIR

- Max dia: 3,600mm.
- Remove/replace trunnion roller bearings using oil injection and specialized extraction and bearing installation jigs.
- Scrape in white-metal/bronze bearings.



RE-MACHINING TRUNNION FLANGE FACES

- Max dia: 14,000mm.
- On-site removal & installation of trunnion.
- On-site refurbishment & machining of mill trunnions.



SPECIALISED INSPECTION EQUIPMENT

- Full dimensional inspections done on-site
 - Diameters, lengths, hole PCD
 - Full gear inspection including:
 - Pitch - Lead - Involute
- Hardness testing, crack detection and material chemical analysis.



CRUSHER MAINTENANCE

Planned or unforeseen shutdowns:
Experienced site services team for installations, site inspections and commissioning.



DRAGLINE & SHOVEL SITE WORK

- Completely inspect, audit and condition monitor critical dragline and shovel components.
- Complete site installations including machining and welding.



LASER ALIGNING

- Laser alignments of drive trains for mills, kilns, turbines etc.
- Girth gear/pinion installation.
- Gearbox bore laser alignment inspection.
- Engine block crankshaft bore alignment inspection and rectification.



MACHINING GEARBOX MOUNTING FLANGE

- Flange & bore refurbishment.
- Site inspection and drafting.
- Special purpose machinery designed and manufactured to suit your application.
- Bolt tensioning equipment.



LINE BORING, WELDING & ON-SITE MACHINING

- On-site line boring: bucket bores, engine blocks, ship propeller housings, crushers etc.
- Line boring and drilling to 3m dia x 6m L.
- Milling of keyways and surfaces.
- Site welding and heat-treatment.



HPGR MAINTENANCE & CHANGE OUT

Specialist site service teams manage complete HPGR installations, gearbox monitoring and refurbishment service, roller change-out and HPGR machine commissioning as well as complete machine inspection, condition monitoring, in situ repair and overhauling.



TRUNNION & LINER BOLT HOLE REPAIRS

- Purpose manufactured tooling for production drilling/boring and tapping.
- Re-bore and sleeve worn liner bolt holes to prevent liner bolts from breaking.



OIL & GAS RIG EQUIPMENT REPAIRS, ON & OFFSHORE

- On-site machining, fitting & laser alignment.
- Gearbox and gears manufactured and repaired.
- Pump and valves installed and serviced.



KILN TYRE REFRUBISHMENT BY IN SITU GRINDING

- Kiln roller and tyre refurbishment by machining and grinding.
- Crusher rolls in situ grinding to remove uneven wear.

KILN SERVICES



- Consultation
- Inspections
- Alignment services
- Refurbishments
- Tyre/Roller surface reconditioning
- Gear installations
- Maintenance planning

WORLDWIDE KILN SERVICES



ALIGNMENT

- Survey carried out using hard contact and fixed datum methods.
- Tyre and roller diameters are measured during normal operation with the aid of an electronic measuring device that is accurate up to 0.10mm. This allows for accurate profiling of wear conditions and averaging for alignment.
- The aim is to achieve correct alignment of the kilns' actual centre line which is achieved by considering the whole assembly including the mesh of the drive girth gear and pinion.



RECONDITIONING

- Rollers and tyres can be machined, ground, finished or tapered using our purpose built reconditioning unit to recondition tyre and roller surfaces, correcting any uneven wear.
- A purpose built reconditioning unit can be adapted to suit most rotary kiln designs and can be transported worldwide to meet customer requirements.
- Tyre and roller diameters are measured prior to and after reconditioning to confirm profiles are flat and parallel to the centre line axis.



MAINTENANCE PLANNING

- Major maintenance projects need careful planning to ensure timely and correct performance.
- Correct procedure and methods are required in order to achieve optimum equipment performance on start up.
- Alignment tolerances are maintained during installations and repair outages.



1. KILN ALIGNMENT SURVEYING

Survey by hard contact method:

- Check alignment of the kiln.
- Realign kiln to ensure smooth running.



2. ESTABLISHMENT OF KILN CENTRE LINE

This enables datums to be established from which future measurements can be taken.



3. ROLLER ALIGNMENT

Rollers are aligned using the hard contact method from direct centre lines.



4. MEASUREMENT OF ROLLER & KILN TYRES

Diameters are measured electronically with an accuracy of 0.10mm. This forms part of the critical information needed to give correct kiln alignment.



5. MACHINING TYRES & ROLLERS

Kiln tyres and rollers can be machined or ground on-site.



6. SHELL CHANGEOUT AND/OR STRAIGHTENING

- Kiln shells up to 15m dia. can be measured on-site and manufactured by Hofmann Engineering.
- The Hofmann Engineering site team can perform shell change-outs and straightening using in situ sub arc welding.



7. GIRTH GEARS

The manufacture, installation, reversal, reconditioning and alignment of kiln girth gears can be supplied:

- Site measure pinions and gears.
- Manufacture complete gearing in-house.
- Install and align with Hofmann's site crew.
- Site gear reconditioning available.
- Hofmann open gear lubrication.

METROLOGY, METALLURGY & DESIGN SERVICES

- QUALITY CONTROL • INSPECTION • METAL TESTING
- SPECTROGRAPHY • N.D.T. • DESIGN • FEA

ON-SITE IN SITU INSPECTION

Hofmann Engineering is committed to the highest quality and has a focus on pushing the boundaries of existing technology.

Quality can only be achieved if it can be measured accurately. On-site, in situ metrology methods are a cost effective and efficient option to measure wear, problem solve and measure up for a new replacement part.

Hofmann Engineering have invested in a variety of equipment including Portable Coordinate Measuring Machines (PCMMs), laser scanners and laser trackers.

The PCMMs achieve an accuracy of 20µm (0.001") and run a number of different software applications for general inspection and a unique gear inspection software.

The laser scanner attaches to the head of the PCMMs and produces a laser scanned point cloud from which a model can be created.

The laser trackers have a 320m radial measuring envelope producing micron accuracy on large parts such as mill heads, gearbox casing and slew gears.

With such a range of metrology equipment, Hofmann Engineering has an accurate metrology solution for each situation.



PCMM ON A MILL PINION



LASER TRACKER ON A MILL HEAD



PCMM ON TRACK PADS



LASER TRACKER ON A GEARBOX CASING



LASER
SCANNER



CMM LABORATORY INSPECTION

A state-of-the-art, climate controlled and vibrationally isolated inspection laboratory houses the fixed CMM. With accuracy to $2\mu\text{m}$, the CMM has the capability, software and accreditation to inspect gears to 6m diameter, small to large mill pinions, aerospace parts, worm gearing, bevel gears and many other components.

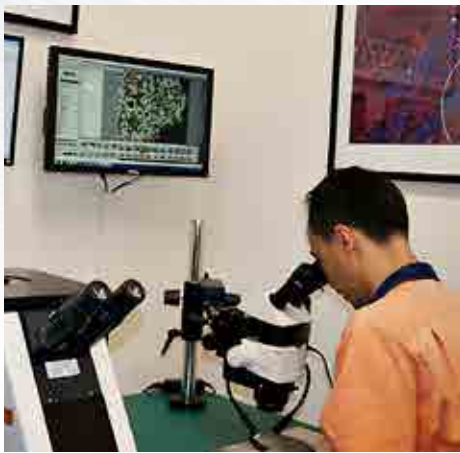

METALLURGY

Complete metallurgical lab for:

- Quality control of heat treatment processes;
- Metallurgical failure analysis.

Specialising in failure analysis of gearing to AGMA and DIN standards.

SPECTROGRAPHIC ANALYSIS

Full chemical composition analysis of carbon and alloy steels; stainless steel; copper; and nickel alloys. Ideal for material identification and weld procedure specification.

NDT INSPECTION

- In-House NDT capabilities for defect identification and quality control.
- ISO 9712 Certified Technicians.

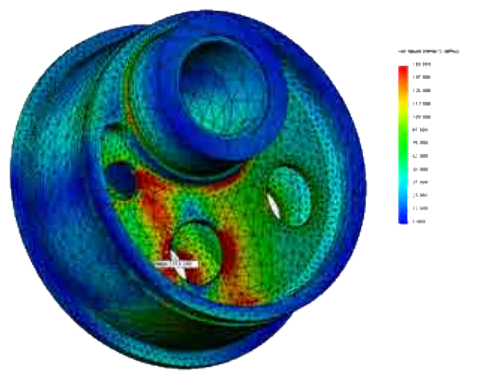
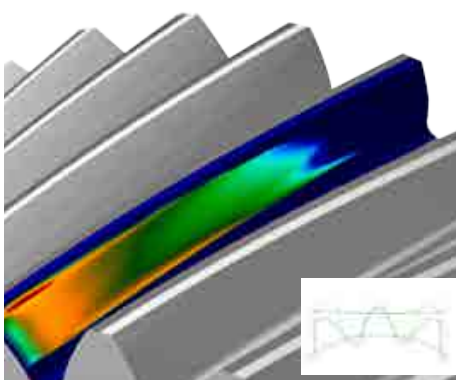
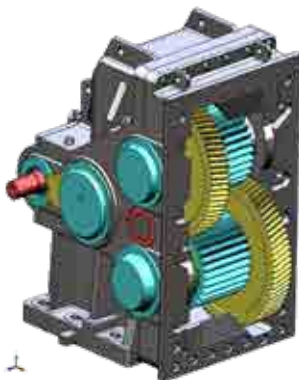

ENGINEERING DESIGN

- 2D and 3D CAD to produce manufacturing drawings.
- 5-axis CAM to program machining.

Designs for a wide variety of components are completed, including complex gearing, aerospace tooling, HPGR's, and track pads.

Programs: AutoCAD, Solidworks, Unigraphics NX CAD/CAM, PEPS, Catia v5, CADD5, and Pro_E.

GEAR DESIGN & ANALYSIS

Gear tooth optimisation; contact pattern and modification analysis to produce quiet and efficient running gearing.

- Shaft and bearing calculations.
- Typical design components: spur, helical and double helical gears and splines; planetary gear trains; straight, skew, spiral, zerol and hypoid bevel gearing; worm gearing; special tooling; and flexible couplings.

Programs: KISSsoft and TBK.

FINITE ELEMENT ANALYSIS (FEA)

- Static and dynamic FEA simulations can be performed.
- Special gear tooth FEA programs to analyse cracks in cast gearing.

Typical applications: gearbox casings; Hofmann re-designed components; cast gearing; rope drums; and eccentrics

WORKSHOP CAPACITIES

MAXIMUM CAPACITY

TURNING	4,100mm dia. x 10,000mm long / 1,870mm dia. x 35,000mm long
GRINDING	Cylindrical Roll Grinding to 1,000mm dia. x 10,000mm long
HORIZONTAL BORING	22,000mm x 5,000mm x 2,000mm
VERTICAL BORING	15,000mm diameter
HIGH VOLUME PRODUCTION MACHINERY	5-axis CNC Machining Centres up to 22,000mm x 5,000mm
GEAR GRINDING	
Climate controlled environment	Accuracy to DIN 2 (AGMA 15)
CNC Gear Form Grinders	Internal and external gears to 2,400mm dia. x 1,500mm face width
GEAR CUTTING	
Climate controlled environment:	Accuracy to DIN 5 (AGMA 12)
External Gears:	15,000mm dia. x 2,500mm face width (3 units; 15m, 14m, 11m dia.)
Internal Gears:	15,000mm OD x 500mm face width
Worms & worm gears:	4,000mm dia. x 30 module
Bevel gears (Spiral/Slew/Straight):	4,000mm dia. x 310mm face width (DIN 3)
Sprockets:	15,000mm dia.
Crown Gear Couplings:	2,000mm dia. x 1,000mm face width
Double helical gears:	14,000mm dia. x 2,500mm face width
INSPECTION	
Climate controlled environment	Full gear inspection. Measuring Accuracy MPEp (ISO 10360-2) = 2.0µm. Envelope dimensions: 3,000mm x 1,500mm x 1,000mm plus 16t rotary table Portable CMM's with Gear Inspection software Laser Scanners
DESIGN & ENGINEERING SERVICES	CAD, CAM and FEA including SolidWorks and Kisoft Gear Design Software
HEAT TREATMENT	Full metallurgical laboratory for failure analysis
Atmosphere controlled:	Gas carburising: - Pit furnaces and fluidised bed. 1,900mm dia. x 5,000mm Induction hardening: - Tooth by tooth induction hardening machine. Gears, pinions, track pads. Full contour profile up to 15,000mm dia. Quench and tempering: - Oil tank 30,000L 1,900mm x 5,000mm long - Water/polymer quench Nitriding: - Carbo nitriding Furnace 900mm dia. x 1,800mm - Nitro carburising Furnace 900mm dia. x 1,800mm Tool Steels: - Fluidised bed 1200°C Furnace 900mm dia. x 1,800mm Tempering Furnace 6,000mm dia. x 3,000mm Stress relieving - Gas Furnace 15,000mm x 15,000mm wide Stress relieving - Electric Furnace 12,000mm dia. x 2,000mm Marquench Shot-peening Sandblasting
FABRICATION/WELDING	Fabricated gears, transmission boxes and mining equipment - 200 tonnes. Plate Rolls 6,000t, 3,650mm width x 220mm thick 4,000t, 3,200mm width x 150mm thick
PRODUCT SUPPORT AND FIELD SERVICE	
LUBRICATION AND CONDITION MONITORING	
QUALITY ASSURANCE	Certified to ISO9001 and AS9100 by Lloyds
LIFTING & HANDLING	Overhead Gantry Cranes to 200 tonnes Yard Cranes & Straddle Carrier Forklifts

The above capacities are indicative only, please contact us with your specific requirements.
Information supplied is subject to change without notice.

**SERVING INDUSTRY
FOR 50 YEARS**
with
ENGINEERING SOLUTIONS



**THREE
GENERATIONS**



ONE FAMILY



**AUSTRALIAN
OWNED**



WORLDWIDE

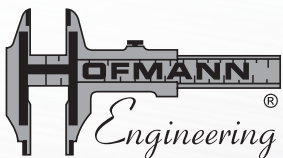

HOFMANN ENGINEERING PTY LTD

HEAD OFFICE

3 Alice Street, Bassendean (Perth), Western Australia 6054

P: (+61) 8 9279 5522 **F:** (+61) 8 9279 9386 **E:** mail@hofmannengineering.com **W:** www.hofmannengineering.com

AUSTRALIA: PERTH | MELBOURNE | BENDIGO | NEWCASTLE

INTERNATIONAL: CHILE | PERU | INDIA | CHINA | NORTH AMERICA